



U.S. Tsubaki, Inc.

Engineering Chain Division

Asphalt Batch Plant Processing

- Reduce downtime
- Increase profitability
- Improve operations

The right mi

Asphalt is tough! Hard aggregates, shock loads, intense heat, and almost around-the-clock operation during the paving season mean every component in your operation has to perform. Union chain from U.S. Tsubaki delivers.

U.S. Tsubaki hit the road around the world to bring you the strongest, longest-lasting asphalt chains. Each is built exactly to Union specifications, offering these critical benefits: tight press fits and precise pitch control, increased strength, and longer service life.

Choose U.S. Tsubaki for:

- High-quality, long-lasting operations
- Reliable performance even with high shock loads
- Durable operation in tough conditions
- Decreased downtime and fewer unplanned stops

Incline Conveyor Chains

Available in 4" or 6" pitch with K- or slotted M-style attachments. These chains are constructed for maximum strength and longevity. Sidebars are thru hardened to stand up to high impact loads. And rollers are specially heat treated to resist abrasion in even the toughest operating conditions.

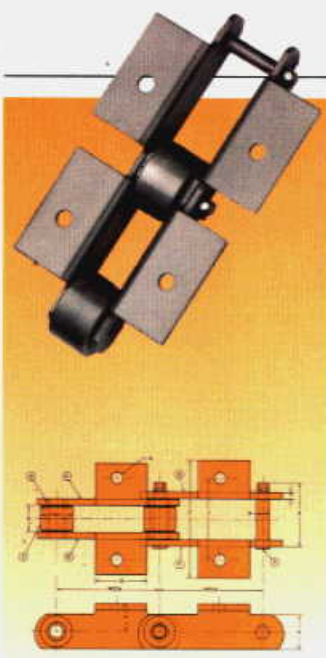
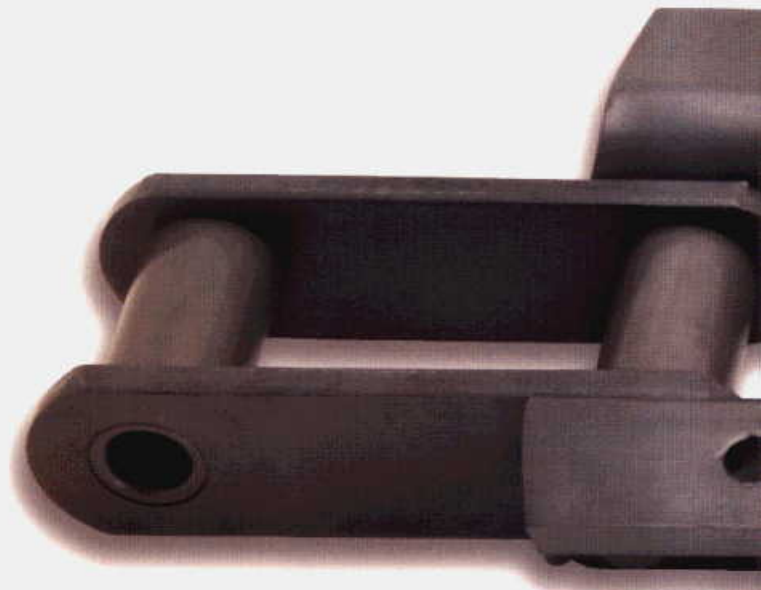

K-11 Style Attachment



K-1/K-2 or K-3 Style Attachment

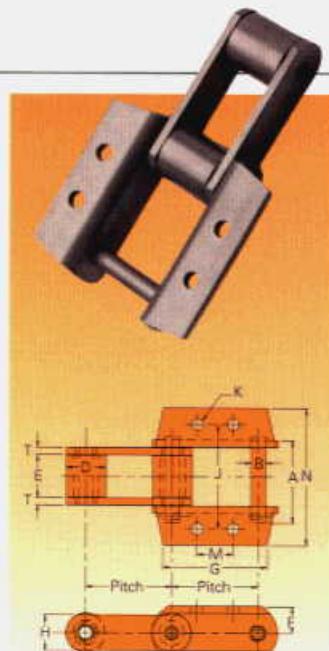

K-2 or K-44 Style Attachment

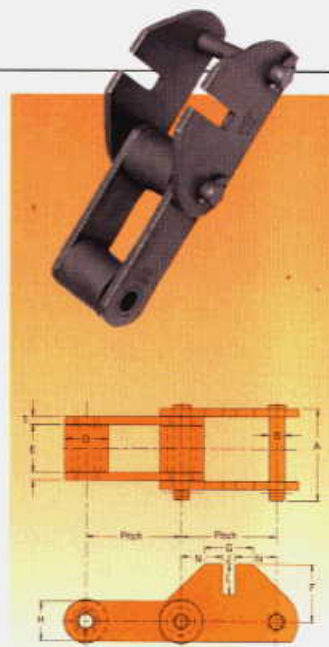

MM-1 Style Attachment

Key for success



Incline Conveyor Chart

Drwg #	Description	Pitch	Pin		Inside Width	Roller Dia.	Sidebar		Attachment							Bolt Dia.	Average Tensile Strength	Max. Work Load (lbs.)	Approx. Weight (lbs./ft.)
			A	B			E	D	H	T	F	G	M	N	J				
P-10024	2111/K-11 E/Pitch	6	3.69	0.75	1.56	1.88	2.00	0.38	1.63	3.00	—	6.79	4.75	—	0.69	83,000	5,900	12.1	
P-10020	U-3945/K-3 E/3rd Pitch	4	3.75	0.63	2.00	1.25	1.50	0.31	1.38	5.63	1.75	6.50	5.31	4.75	0.44	44,000	5,740	9.8	
P-10021	U-3952/K-2 * E/3rd Pitch	4	4.13	0.75	2.00	1.44	1.75	0.38	1.63	6.00	1.75	6.69	5.50	—	0.53	60,000	7,220	12.8	
P-10022	3433 w/K-1/K-2 E/3rd (1.5" roller)	4	4.13	0.63	2.13	1.50	1.50	0.38	1.00	2.82	1.75	4.84	5.31	4.75	0.41	40,000	6,300	9.7	
P-10023	U-3940/K-2 E/2nd Pitch	6	4.06	0.75	2.00	1.63	2.25	0.38	2.00	7.38	2.31	7.78	6.25	—	0.56	90,000	7,220	14.8	
P-10025	856/K-24 E/2nd Pitch	6	5.75	1.00	3.00	—	2.50	0.50	1.88	7.25	2.50	9.50	7.25	—	0.75	145,000	14,000	16.5	
P-10026	U-9856/K-44 E/2nd Pitch	6	5.75	1.00	3.00	2.75	2.50	0.50	1.88	7.25	2.50	9.52	7.25	—	0.81	140,000	14,000	30.0	
P-10027	U-9856/MM-1' E/2nd Pitch	6	5.75	1.00	3.00	2.75	2.50	0.50	3.75	3.06	—	2.59	0.81	2.75	—	140,000	14,000	29.1	

¹Verify attachment sidebar slot width and depth dimensions prior to ordering
^{*} Square hole on attachment

U.S. Tsubaki

Engineered for Asphalt Operations

The fastest way
through
road construction...
Call today

Complete Solutions for the Asphalt Industry

- Incline Conveyor Chains
- Bucket Elevator Chains
- Engineering Class Drive Chains
- Apron Conveyor Chains
- Paver Chains
- Sprockets
- Pro-Align™ Laser Alignment System
- ONE-TOUCH INSPECTION DOOR®



U.S. Tsubaki, Inc.

Corporate Headquarters
301 E. Marquardt Drive
Wheeling, IL 60090
Tel: (800) 323-7790
Tel: (847) 459-9500
Fax: (847) 459-9515

Web Site: www.ustsubaki.com

Engineering Chain Division
1010 Edgewater Drive
Sandusky, OH 44870
Tel: (800) 537-6140
Tel: (419) 626-4560
Fax: (419) 626-5194

Distributed by:

NOTE: IN ACCORDANCE WITH THE POLICY OF U.S. TSUBAKI, INC., TO CONSISTENTLY IMPROVE ITS PRODUCTS, THE SPECIFICATIONS IN THIS BROCHURE ARE SUBJECT TO CHANGE WITHOUT NOTICE. **FOR CURRENT TERMS AND CONDITIONS OF SALE, SEE OUR ENGINEERING CHAIN GENERAL CATALOG.**

ONE-TOUCH INSPECTION DOOR® is a registered trademark of Tsubaki Conveyor of America, Inc.

© U.S. Tsubaki, Inc. 2000 All Rights Reserved. Printed in the U.S.A. 10/00 L10842