

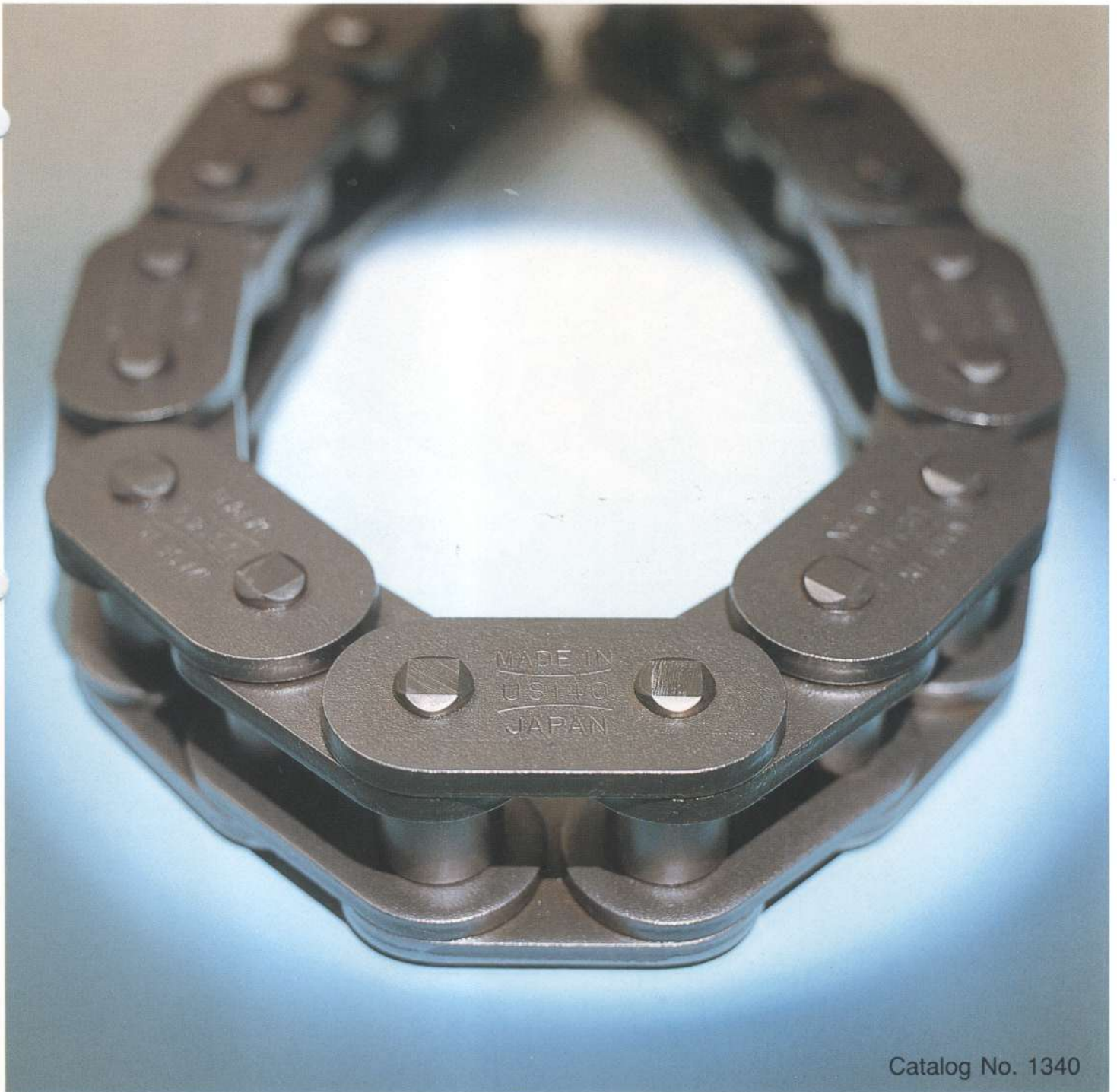

TSUBAKI SUPER CHAIN SERIES



Catalog No. 1340

SUPER CHAIN —

ANSI standard roller chains are widely used in various industries. To meet growing demands of industry for cost efficiency; stronger and higher performing chains which can replace the corresponding ANSI standard chains are necessary. TSUBAKI offers a line of Super and Ultra Super Chains which will solve your specific driving and conveying problems that involve to heavy shock loads and space limitations.

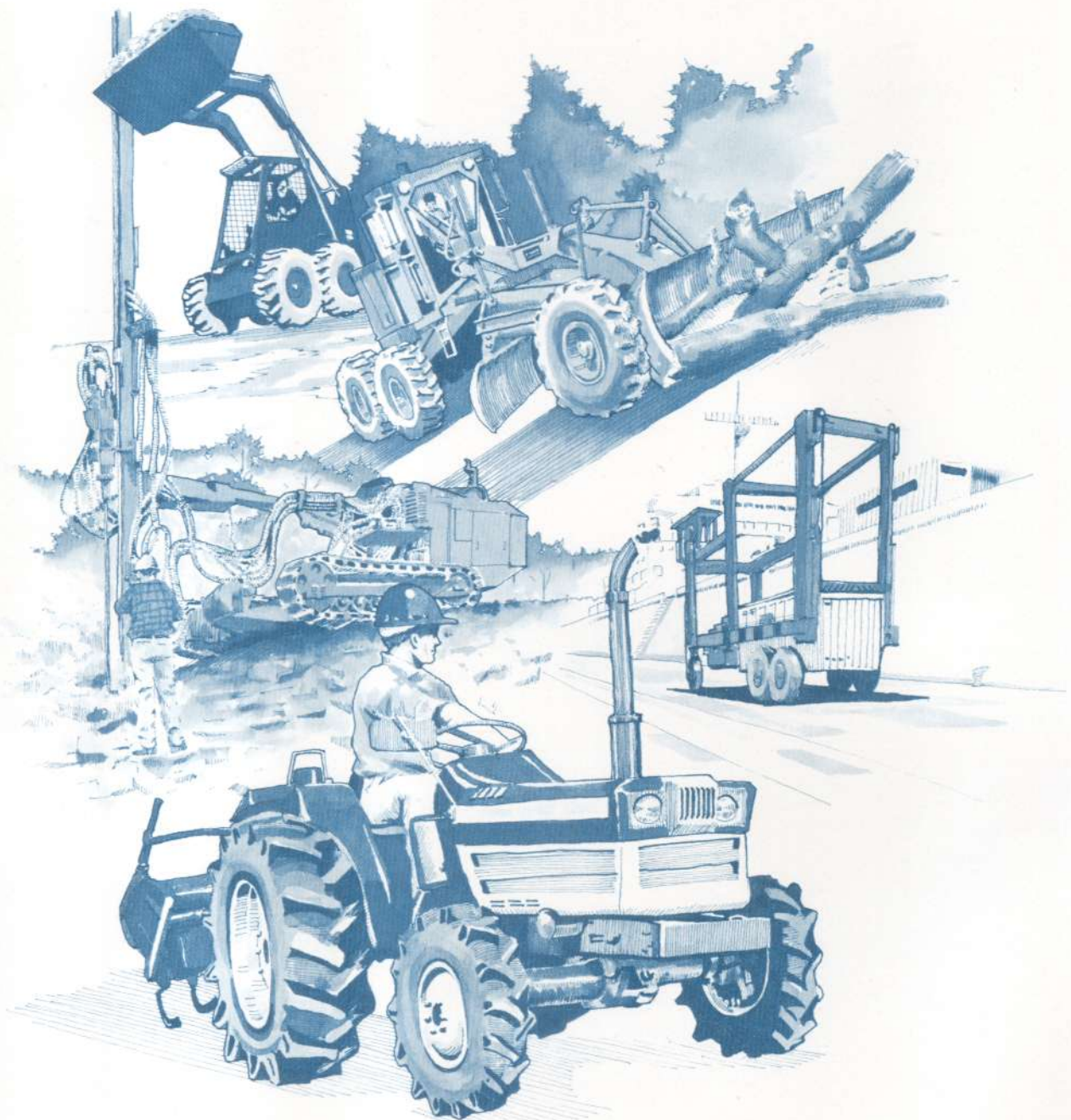

Proven Performance

T Series

T Series chains have greater shock load resistance and higher ultimate tensile strength than comparable ANSI standard roller chains due to the employment of through hardened pins. The dimensions of the chains are identical to ANSI standard roller chains.

HT Series

HT Series chains have a greater ultimate tensile strength (plus 15~30%) over ANSI standard roller chains by using through hardened pins and link plates of the next larger chain size. These chains also provide greater shock load resistance. The dimensions of the chains are identical to ANSI Heavy Series standard roller chains.

SUPER Series

The dimensions of this series are identical to those of ANSI standard roller chains. Link plates of the Super Series have a special design and the pitch holes are critically formed to improve their allowable load by 25~30%. The pins are through hardened for greater shock load resistance.

SUPER-H Series

The thickness of the link plates of Super-H Series is the same as that of the next larger size of SUPER Series chain and the pins are through hardened. As a result, the chains have greater ultimate tensile strength and allowable load than Super Series Chains.

ULTRA SUPER Series

Field test results show that Tsubaki Ultra Super Series has greater ultimate tensile strength and allowable load than any other roller chain manufactured. As the allowable load is 170% of that of ANSI RS standard roller chain, using Ultra Super Series allows selection of a chain of up to two sizes smaller than the suitable standard chain. Excellent for applications where heavy shock loads or space limitations pose problems.

If you've had problems such as fatigue breakage of link plates, generally poor performance, or space limitation,

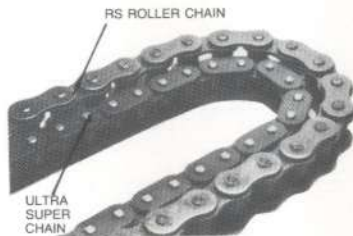

we recommend that you try the Tsubaki HT Series, Super Series, Super-H Series or the Ultra Super Series where you may use the next smaller size or even a roller chain two sizes smaller than the standard choice.

Tsubaki Super Chain Features

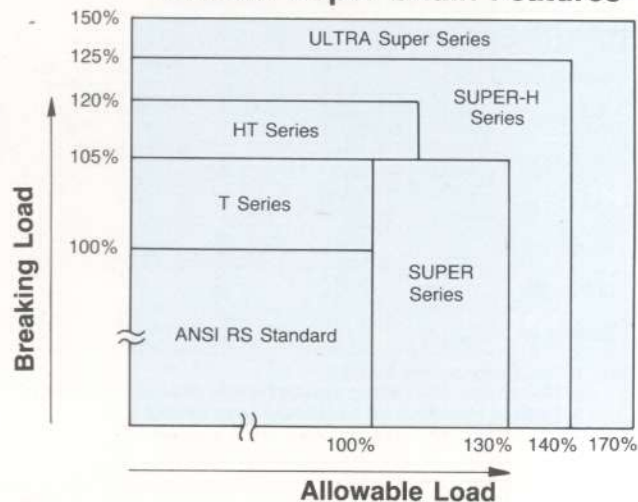

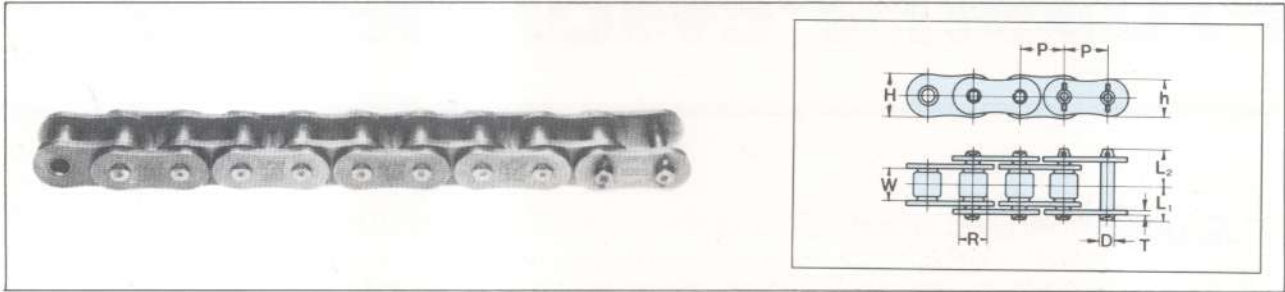

Upper dimension – inch
Lower dimension – mm

TSUBAKI Chain No.	Pitch P	Roller Dia. R	Width Between Roller Link Plates W	Link Plate				Pin		Average Tensile Strength	Maximum Allowable Load	Approx. Weight
	P	R	W	T	H	h	D	L ₁	L ₂	lbs./kgf	lbs./kgf	lbs./ft. kgf/m

RS-T Series

RS 60T	3/4 19.05	.469 11.91	1/2 12.70	.094 2.4	.713 18.1	.614 15.6	.234 5.96	.506 12.85	.581 14.75	10,300 4,700	1,980 900	1.03 1.53
RS 80T	1 25.40	.625 15.88	5/8 15.88	.125 3.2	.949 24.1	.819 20.8	.312 7.94	.640 16.25	.758 19.25	17,600 8,000	3,300 1,500	1.79 2.66
RS100T	1-1/4 31.75	.750 19.05	3/4 19.05	.156 4.0	1.185 30.1	1.024 26.0	.375 9.54	.778 19.75	.900 22.85	27,300 12,400	5,070 2,300	2.68 3.99
RS120T	1-1/2 38.10	.875 22.23	1 25.40	.187 4.8	1.425 36.2	1.228 31.2	.437 11.11	.980 24.9	1.138 28.9	39,700 18,000	6,830 3,100	3.98 5.93
RS140T	1-3/4 44.45	1.000 25.40	1 25.40	.219 5.6	1.661 42.2	1.433 36.4	.500 12.71	1.059 26.9	1.248 31.7	52,900 24,000	9,040 4,100	5.03 7.49
RS160T	2 50.80	1.125 28.58	1-1/4 31.75	.250 6.4	1.898 48.2	1.638 41.6	.562 14.29	1.254 31.85	1.451 36.85	68,300 31,000	11,900 5,400	6.79 10.10
RS200T	2-1/2 63.50	1.562 39.68	1-1/2 38.10	.312 8.0	2.374 60.3	2.047 52.0	.781 19.85	1.535 39.0	1.764 44.8	105,800 48,000	16,000 7,300	11.04 16.49
RS240T	3 76.20	1.875 47.63	1-7/8 47.63	.375 9.5	2.850 72.4	2.457 62.4	.937 23.81	1.886 47.9	2.185 55.5	154,300 70,000	22,200 10,100	16.46 24.50

Note: Riveted type chain will be provided unless otherwise specified.
Cottered type chain will be provided upon request.

RS-HT Series

RS 60HT	3/4 19.05	.469 11.91	1/2 12.70	.125 3.2	.713 18.1	.614 15.6	.234 5.96	.583 14.8	.669 17.0	12,500 5,700	2,200 1,000	1.21 1.80
RS 80HT	1 25.40	.625 15.88	5/8 15.88	.156 4.0	.949 24.1	.819 20.8	.312 7.94	.720 18.3	.823 20.9	20,900 9,500	3,640 1,650	2.08 3.11
RS100HT	1-1/4 31.75	.750 19.05	3/4 19.05	.187 4.8	1.185 30.1	1.024 26.0	.375 9.54	.858 21.8	.965 24.5	31,900 14,500	5,510 2,500	3.07 4.58
RS120HT	1-1/2 38.10	.875 22.23	1 25.40	.219 5.6	1.425 36.2	1.228 31.2	.437 11.11	1.061 26.95	1.203 30.55	43,000 19,500	7,280 3,300	4.38 6.53
RS140HT	1-3/4 44.45	1.000 25.40	1 25.40	.250 6.4	1.661 42.2	1.433 36.4	.500 12.71	1.138 28.9	1.303 33.1	56,200 25,500	9,590 4,350	5.54 8.27
RS160HT	2 50.80	1.125 28.58	1-1/4 31.75	.281 7.15	1.898 48.2	1.638 41.6	.562 14.29	1.337 33.95	1.514 38.45	71,600 32,500	12,600 5,700	7.35 10.97
RS200HT	2-1/2 63.50	1.562 39.68	1-1/2 38.10	.375 9.5	2.374 60.3	2.047 52.0	.781 19.85	1.689 42.9	1.894 48.1	125,600 57,000	17,600 8,000	12.33 18.41
RS240HT	3 76.20	1.875 47.63	1-7/8 47.63	.500 12.7	2.850 72.4	2.457 62.4	.937 23.81	2.157 54.8	2.453 62.3	198,400 90,000	25,400 11,500	19.57 29.13

Note: Riveted type chain will be provided unless otherwise specified.
Cottered type chain will be provided upon request.

SUPER Series

SUPER 80	1 25.40	.625 15.88	5/8 15.88	.125 3.2	.949 24.1	.819 20.8	.312 7.94	.640 16.25	.758 19.25	19,100 8,700	4,180 1,900	1.91 2.81
SUPER100	1-1/4 31.75	.750 19.05	3/4 19.05	.156 4.0	1.185 30.1	1.024 26.0	.375 9.54	.778 19.75	.900 22.85	28,600 13,000	6,830 3,100	2.90 4.25
SUPER120	1-1/2 38.10	.875 22.23	1 25.40	.187 4.8	1.425 36.2	1.228 31.2	.437 11.11	.980 24.9	1.138 28.9	41,800 19,000	8,810 4,000	4.30 6.30
SUPER140	1-3/4 44.45	1.000 25.40	1 25.40	.219 5.6	1.661 42.2	1.433 36.4	.500 12.71	1.059 26.9	1.248 31.7	55,100 25,000	12,100 5,500	5.48 8.04
SUPER160	2 50.80	1.125 28.58	1-1/4 31.75	.250 6.4	1.898 48.2	1.638 41.6	.562 14.29	1.254 31.85	1.451 36.85	70,500 32,000	15,800 7,200	7.36 10.79
SUPER200	2-1/2 63.50	1.562 39.68	1-1/2 38.10	.312 8.0	2.374 60.3	2.047 52.0	.781 19.85	1.535 39.0	1.764 44.8	113,500 51,500	21,100 9,600	12.02 17.63
SUPER240	3 76.20	1.875 47.63	1-7/8 47.63	.375 9.5	2.850 72.4	2.457 62.4	.937 23.81	1.886 47.9	2.185 55.5	165,300 75,000	29,700 13,500	17.48 25.63

Note: 1. Offset links are not available.
2. Riveted type chain will be provided unless otherwise specified.
3. Cottered type chain will be provided upon request.
4. Press-fitted type connecting links will be supplied.

Upper dimension – inch
Lower dimension – mm

TSUBAKI Chain No.	Pitch P	Roller Dia. R	Width Between Roller Link Plates W	Link Plate			Pin		Average Tensile Strength lbs./kgf	Maximum Allowable Load lbs./kgf	Approx. Weight lbs./ft. kgf/m
				T	H	h	D	L ₁			

SUPER-H Series

SUPER 80H	1	.625	5/8	.156	.949	.819	.312	.720	.823	22,000	4,630	2.21
	25.40	15.88	15.88	4.0	24.1	20.8	7.94	18.3	20.9	10,000	2,100	3.29
SUPER100H	1-1/4	.750	3/4	.187	1.185	1.024	.375	.858	.965	32,600	7,280	3.28
	31.75	19.05	19.05	4.8	30.1	26.0	9.54	21.8	24.5	14,800	3,300	4.88
SUPER120H	1-1/2	.875	1	.219	1.425	1.228	.437	1.061	1.203	44,000	9,480	4.66
	38.10	22.23	25.40	5.6	36.2	31.2	11.11	26.95	30.55	20,000	4,300	6.94
SUPER140H	1-3/4	1.000	1	.250	1.661	1.433	.500	1.138	1.303	57,300	12,800	5.97
	44.45	25.40	25.40	6.4	42.2	36.4	12.71	28.9	33.1	26,000	5,800	8.88
SUPER160H	2	1.125	1-1/4	.281	1.898	1.638	.562	1.337	1.514	72,700	16,500	7.88
	50.80	28.58	31.75	7.15	48.2	41.6	14.29	33.95	38.45	33,000	7,500	11.72
SUPER200H	2-1/2	1.562	1-1/2	.375	2.374	2.047	.781	1.689	1.894	134,400	22,500	13.22
	63.50	39.68	38.10	9.5	60.3	52.0	19.85	42.9	48.1	61,000	10,200	19.68
SUPER240H	3	1.875	1-7/8	.500	2.850	2.457	.937	2.157	2.453	207,200	31,300	20.47
	76.20	47.63	47.63	12.7	72.4	62.4	23.81	54.8	62.3	94,000	14,200	30.47

- Note: 1. Offset links are not available.
2. Riveted type chain will be provided unless otherwise specified.
3. Cottered type chain will be provided upon request.
4. Press-fitted type connecting links will be supplied.

ULTRA SUPER Series

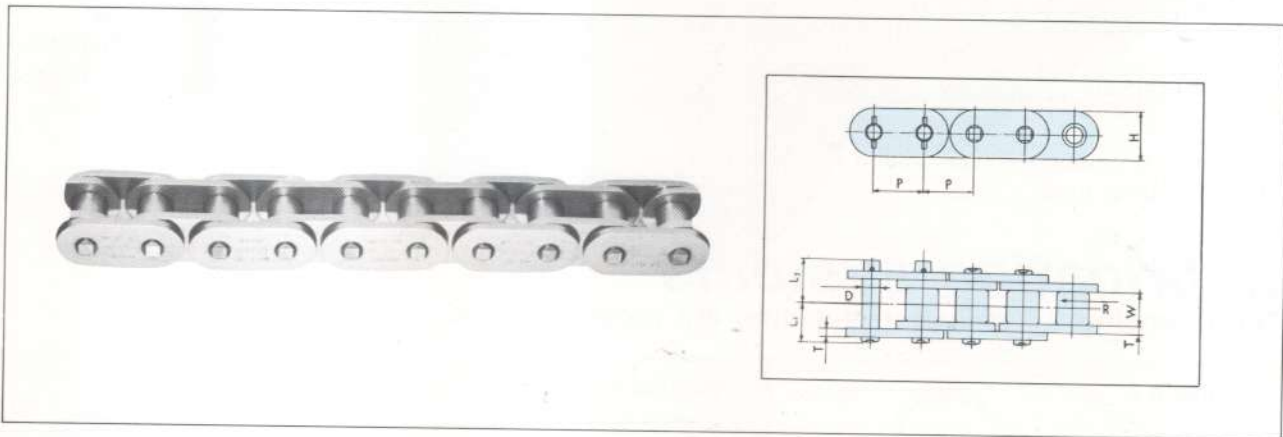

Upper dimension – inch
Lower dimension – mm

TSUBAKI Chain No.	Pitch P	Roller Dia. R	Width Between Roller Link Plates W	Link Plate			Pin		Average Tensile Strength lbs./kgf	Maximum Allowable Load lbs./kgf	Approx. Weight lbs./ft. kgf/m
				T	H	D	L ₁	L ₂			
US100	1-1/4	.750	3/4	.187	1.185	.406	.879	.998	38,500	8,800	3.40
	31.75	19.05	19.05	4.8	30.1	10.32	22.35	25.35	17,500	4,000	5.07
US120	1-1/2	.875	1	.219	1.425	.483	1.085	1.242	55,000	12,100	4.84
	38.10	22.23	25.40	5.6	36.2	12.28	27.55	31.55	25,000	5,500	7.22
US140	1-3/4	1.000	1	.250	1.661	.550	1.161	1.346	70,400	14,300	6.20
	44.45	25.40	25.40	6.4	42.2	13.97	29.50	34.20	32,000	6,500	9.24
US160	2	1.125	1-1/4	.279	1.898	.614	1.358	1.582	88,000	19,140	8.17
	50.80	28.58	31.75	7.1	48.2	15.62	34.5	40.2	40,000	8,700	12.19
US200	2-1/2	1.562	1-1/2	.374	2.374	.803	1.690	2.005	149,600	24,200	13.73
	63.50	39.68	38.10	9.5	60.3	20.41	42.95	50.95	68,000	11,000	20.47
US240	3	1.875	1-7/8	.500	2.850	.973	2.157	2.555	220,000	33,880	21.25
	76.20	47.63	47.63	12.7	72.4	24.73	54.8	64.9	100,000	15,400	31.69

- Note: 1. RS Standard Sprockets can be used if the sprocket teeth have been hardened and the sprocket is not of cast-iron type.
2. Chain should be lubricated using:
a. drip method b. oil bath c. lubrication pump
3. Offset links are not available.
4. Riveted type chain will be supplied unless otherwise specified.
5. Cottered type chain will be provided upon request.
6. Press-fitted type connecting links will be supplied.
7. Chains are not inter-couplable with RS standard chains.

CHAIN DRIVE SELECTION

Generally, Super Series chains are recommended when the chain speed is less than 160 ft./min. (50 m/min.) and where RS Roller Chains or ANSI Heavy Series Chains are not strong enough to meet the application requirements.

- 1) Tentatively select the chain and sprocket with the same size and number of teeth as used in "Selection for slow speed" on page 11 of Tsubaki's general catalog.
- 2) Calculate the chain speed from the number of teeth of the driving sprocket using Equation (A) and check whether the speed is less than 160 ft./min. (50 m/min.).
- 3) Calculate the chain tension necessary for the above drive from Equation (B).
- 4) Select the service factor and the chain speed coefficient from Tables I and II.
- 5) Select the suitable chain and verify that the chain satisfies Equation (C).

$$S = \frac{P \cdot N \cdot n}{12} \text{ (ft./min.) or } \frac{P \cdot N \cdot n}{1,000} \text{ (m/min.)} \dots\dots\dots (A)$$

$$T = \frac{33,000 \times \text{HP}}{S} \text{ (lbs.) or } \frac{6,120 \times \text{KW}}{S} \text{ (kgf)} \dots (B)$$

$$T \times \text{Service Factor} \times \text{Chain Speed Coefficient} \leq \text{Max. Allowable Load} \dots\dots\dots (C)$$

- S: chain speed (ft./min. or m/min.)
- P: chain pitch (inch or mm)
- N: number of teeth of driving sprocket
- n: rpm of driving sprocket
- T: chain tension (lbs. or kgf)
- HP (KW): power to be transmitted (HP or KW)

Table I: Service Factor

Type of Impact	Service Factor
No impact	1.0
Some impact	1.3
Large impact	1.5

For details, refer to Table I on page 10 of Tsubaki's general catalog.

Table II: Chain Speed Coefficient

Chain Speed	Speed Coefficient
Less than 50 ft./min. (15 m/min.)	1.0
50 ~ 100 ft./min. (15 ~ 30 m/min.)	1.2
100 ~ 160 ft./min. (30 ~ 50 m/min.)	1.4

Note: Super Chains can also be used at chain speeds of more than 160 ft./min. (50 m/min.). Please consult Tsubaki.

Selection Based on Expected Life

For some application requirements, the "expected life selection" method will be suitable. Please consult Tsubaki.

Lubricating systems

The following 3 lubricating systems are recommended.

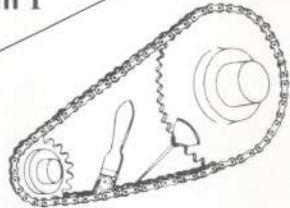
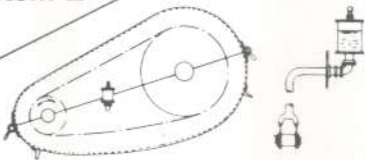
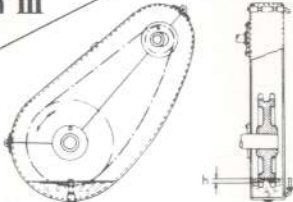
<p>System I</p> 	<p>Manual Application</p> <p>The oil is applied with an oil can or brush to the gaps between the pins and roller links on the slack side of the chain. It should be applied about every eight hours or as often as necessary to prevent the bearing areas from becoming dry. Chain speed should be below 50 ft./min. (15 m/min.).</p>
<p>System II</p> 	<p>Drip Lubrication</p> <p>A simple casing can be used. The oil is supplied by a drip feed. Each strand of chain should ordinarily receive 5 to 20 drops of oil per minute. The amount is increased as the speed increases. Suitable chain speed is from 50 to 100 ft./min. (15 to 30 m/min.).</p>
<p>System III</p> 	<p>Oil Bath Lubrication</p> <p>The chain is installed in a leak-free casing. The oil depth "h" should be 1/4 to 1/2 inch (6 to 12 mm) deep. If the oil is too deep, it will be adversely affected by the heat generated. Suitable chain speed is from 100 to 160 ft./min. (30 to 50 m/min.).</p>



TSUBAKI SUPER SERIES CHAIN

Link up with quality performance

The superior performance of Tsubaki Super Series Chain is the result of a comprehensive quality control network that begins with selection of the world's finest steel materials. It continues with inspection and analysis of quality and performance in 20 different work areas. At Tsubaki, quality control is not just a one time check; it is a total dedication. It is your assurance of long-lasting and dependable performance.



TSUBAKIMOTO CHAIN CO.

Headquarters

Twin21 MID Tower 36F
1-61, Shiromi 2-chome
Chuo-ku, Osaka 540-6136, Japan
Phone : 06-4790-0121
Facsimile : 06-4790-0142

Internet:

<http://tsubakimoto.com>

Affiliated Companies:

U.S. TSUBAKI, INC.

301 E. Marquardt Drive
Wheeling, IL 60090
U.S.A.
Phone : 847-459-9500
Facsimile : 847-459-9515

TSUBAKI of CANADA LIMITED

1630 Drew Road
Mississauga, Ontario, L5S 1J6
Canada
Phone : 905-676-0400
Facsimile : 905-676-0904

TSUBAKI AUSTRALIA PTY. LTD.

Unit E. 95-101 Silverwater Road
Silverwater, N.S.W. 2141
Australia
Phone : 02-9648-5269
Facsimile : 02-9648-3115

Chain Division

Global Sales & Marketing Department

1-3, Kannabidai 1-chome
Kyotanabe Kyoto 610-0380, Japan
Phone : 0774-64-5022/3/4/5
Facsimile : 0774-64-5212

For further information please
contact the Chain Division.

TSUBAKIMOTO SINGAPORE PTE. LTD.

25 Gul Lane
Jurong
Singapore 629419
Phone : 68610422/3/4
Facsimile : 68617035

TAIWAN TSUBAKIMOTO CO.

No. 7 Feng Sun Keng
Kuei Shan-Hsiang, Taoyuan-Hsien
Taiwan R.O.C.
Phone : 033-293827/8/9
Facsimile : 033-293065

TSUBAKIMOTO EUROPE B.V.

Belder 1, 4704 RK Roosendaal
The Netherlands
Phone : 0165-594800
Facsimile : 0165-549450



Kyotanabe Plant

TSUBAKIMOTO U.K. LTD.

Osier Drive, Sherwood Park
Annesley,
Nottingham NG15 0DX U. K.
Phone : 01623-688-700
Facsimile : 01623-688-789

KONING AANDRIJFTECHNIEK

Waalhaven Z/Z 42
3088 HJ, Rotterdam
The Netherlands
Phone : (10)494-1818
Facsimile : (10)429-4906

Distributed by: