

Contents

Plastic Chain Materials
 RS Single Pitch - Linear Movement
 Double Pitch - Linear Movement
 RS Single Pitch - Curved Movement
 TTP Top Chain - Linear Movement
 TP Top Chain - Linear Movement
 TPH Top Chain - Linear Movement
 MTP Top Chain - Linear Movement
 TN Top Chain - Linear Movement
 TTUP Top Chain - Curved Movement
 TPU Top Chain - Curved Movement
 MTPU Top Chain - Curved Movement
 TPSR Top Chain - Curved Movement
 TNU Top Chain - Curved Movement
 Snap Cover Chain
 ST Type Roller Table Chain
 RT Type Roller Table Chain
 MP Type BelTop Chain
 BTO Type BelTop Chain
 Poly-Steel Chain
 Plastic Chain Material Availability Matrix
 Plastic and Top Chain Selection Guidelines
 Snap Cover Chain Selection and Maintenance
 Roller Table Chain Selection Guidelines
 Conveyor Design Reference Guideline
 Warning Statement
 Index

Page

D-2 - D-3
 D-4 - D-6
 D-6
 D-7
 D-8
 D-9
 D-10
 D-11
 D-12
 D-13
 D-14
 D-15
 D-16
 D-17
 D-18
 D-19
 D-20
 D-21
 D-22
 D-23
 D-24
 D-25 - D-28
 D-29 - D-31
 D-32 - D-34
 D-35 - D-43
 D-44
 D-45

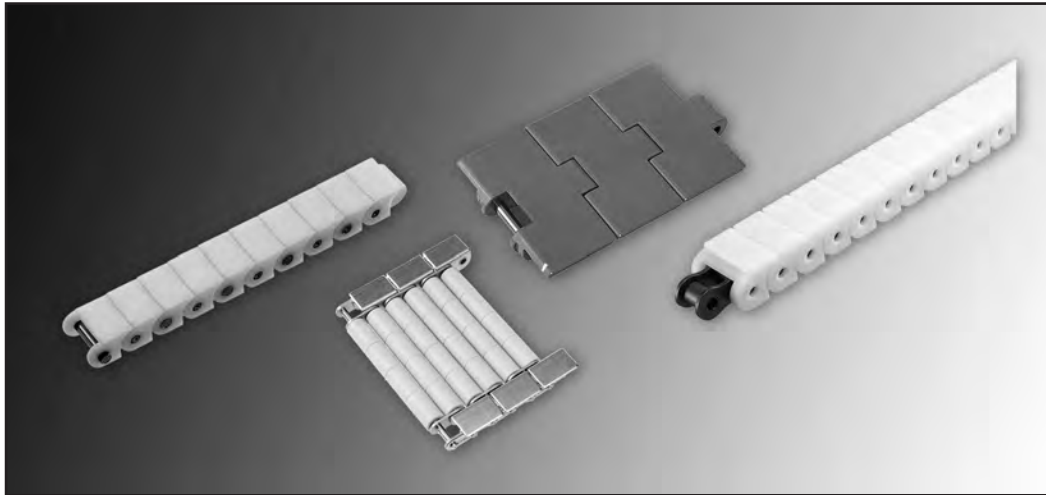

Tsubaki Plastic Chains offer an economical and practical alternative to steel roller chain. Plastic chains move product on the line without scuffs or scratches. Lightweight and offering low maintenance, these strong, long lasting chains set the standard for reliable performance. We have combined our chain expertise with new, innovative plastics to create plastic chains that do more than turn. They solve problems.

Tsubaki Plastic Chains are available in 8 different material types. Need speed? Fighting friction? Is static electricity, bacteria or chemical corrosion costing you time and money? Tsubaki has innovative plastic materials to suit your application.

Tsubaki offers plastic chains to suit many linear and curved conveying applications. From plastic chains that replace steel drive chains, to plastic top chains that convey materials on their top plates, to plastic roller table chains and much much more. Tsubaki Plastic Chains include: RS Chain, Top Chain, Snap-Cover Chain, Roller Table Chain, BelTop Chain and Poly-Steel Chain.

Tsubaki Plastic Chain Materials

Our plastic chains are available in 8 different resin materials. An availability matrix at the back of this section shows which chains are available in each plastic material. The following is an outline of the characteristics and recommended applications for each resin type.

1. Standard Series

Non-slip Applications

Standard series chains are effective in areas where there is not too much slipping. Used in bottling industry for inclined conveyor lines such as the entrance and the exit to bottle warmers. It is also used for single line conveying of empty cans.

2. MW/UMW Series

Low Friction and Ultra Low Friction Applications

Our Low and Ultra Low Friction ("MW" and "UMW") types of plastic chains have a low coefficient of sliding friction. Chains made of this material are ideal for multi-packing lines, bottling/canning lines and PET bottle production facilities.

The "UMW" series of polyacetal material also contains silicon which provides it with a 15% to 35% lower coefficient of friction – with conveyed materials - than "MW" series material.

"MW" series is often used in general accumulating lines to prevent sliding.

"UMW" type is often used in bottling lines between the bottle filler and the bottle warmer areas where the conveyed bottles are gradually slowed down. "UMW" is often used where chain can not be lubricated due to the nature of the conveyed products (eg. paper packaged beverages such as milk and juice).

3. MWS Series

Anti-bacteria/Anti-mold Operations

"MWS" series chains are made of resin compounds that fight the formation of a variety of pathogens. Even if the chain surface wears, the anti-bacterial properties continue to be effective. These chains are suitable for bottling plants where they resist the formation of mold and bacteria in the rinse and sterilization areas. "MWS" type materials are also ideal for food plants where food is conveyed before being sealed. Chains made of "MWS" materials are also suitable for low friction specifications. There is almost no change in power and efficiency due to the anti-bacterial properties that have been added to the plastic.

4. KV Series

High-Temperature, High Speed Conveying Applications

“KV” materials allow chains to operate at high conveying speeds and temperatures that were once impossible for plastic chains. “KV” has heat-resistant qualities comparable to metal. In addition to its heat resistant properties, KV chain properties also make it ideal for high speed, chemical resistance and flame retardant applications. It is often used in beverage can filling around the filler and in the sterilizing and rinsing procedures. They can also be used for high-speed resistance and electrical conduction applications such as those on the inspection and printing line for empty cans prior to filling.

Tsubaki offers two types of “KV” materials (KV180 and KV250) for different temperature applications.

	KV180	KV250
Ambient Operating Temperature (°F)	356	482
Maximum allowable speed (ft./min.)	330*	330*

*denotes that the maximum allowable speed will change at temperatures of 122°F or higher.

5. Y/SY/AR Series

Chemical Applications

Our “Y” and “SY” series chains are made of chemical resistant material that makes the chains ideal for handling the inspection, packaging and cleaning of light electrical appliances/devices. They are also suitable for food items, pharmaceuticals and chemical products.

“Y” series resins are designed to resist chloride, acids, alkalis, oxidizers and most organic solvents.

“SY” series resins resist the same chemicals as the “Y” series above. In addition, chains made of “SY” material use titanium pins provide extra corrosion resistance to strong chemicals including sulfuric acid and hydrochloric acid.

Tsubaki “AR” type materials are manufactured with a chemically resistant plastic covered top and titanium pins that provide even higher levels of chemical resistance than the “Y” and “SY” series. The “AR” series is well suited for bottling plant applications. Chain made using “AR” materials resists lubricants that contain hypochlorous acids such as those used in beverage and beer bottling plants.

6. E/SE Series

Electro-conductive Applications

Where static electricity, dust buildup and sparking are a problem, chains made of “E” and “SE” series resins are ideal. These materials discharge static electricity so that the line will continue to run at optimal conditions.

“E” Series chains are ideal for applications including assembly lines for circuit boards, electronics and monitors. Volume resistance: 1×10^6 ohm • cm

“SE” Series chains are suitable for canning and food conveying. They do not have a high enough resistance to handle circuit boards or electronic components. Volume resistance: 1×10^{13} ohm • cm

7. HF Series

High Friction Applications

Chain made of “HF” materials stabilize product on the line. They are suitable for conveying very light materials such as cans on a vertical vacuum conveyor. “HF” type materials are also used for inclined conveyors found in the bakery and general food industry.

8. UVR Series

Ultraviolet Ray Resistance

Chain made of our “UVR” type material stands up to the damaging effects of ultraviolet rays, such as those used in paint curing and drying lines, or from exposure to sunlight.

Tsubaki Plastic Chain Types

A. Plastic RS Chains

This chain consists of polyacetal chain links and 18-8 stainless steel pins, making it suitable for use in corrosive environments. The RS plastic chain can engage with standard roller chain sprockets. It can be used as a flat top roller conveyor chain and as a replacement for steel roller drive chain. RS plastic chain is available in both linear and curved styles.

RS Single Pitch - Linear Movement Plastic Chain

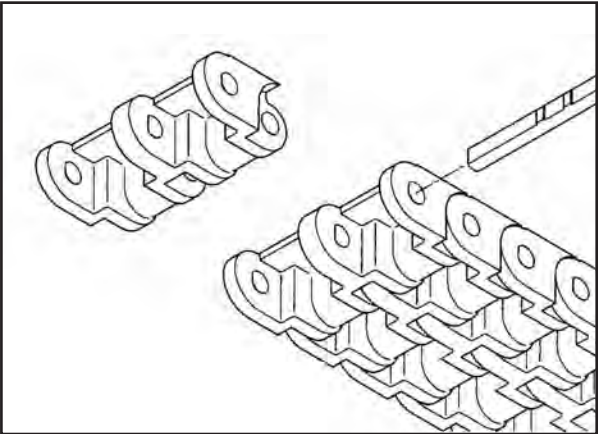
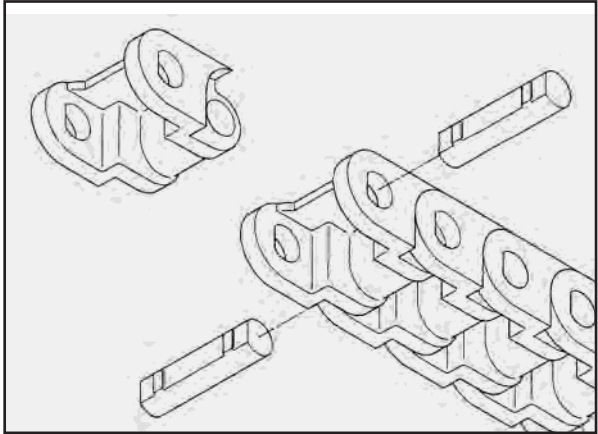
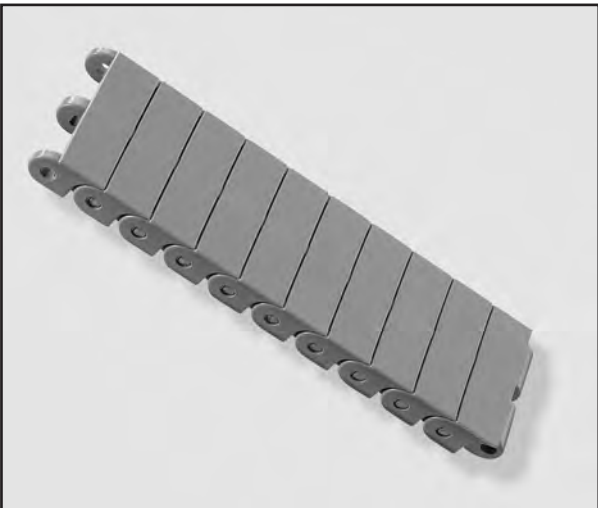
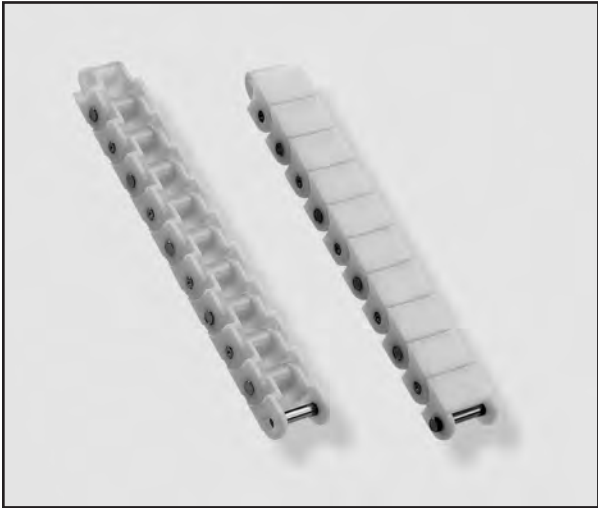

S
e
c
t
i
o
n
D

Single Strand Chain Stainless Steel Pin

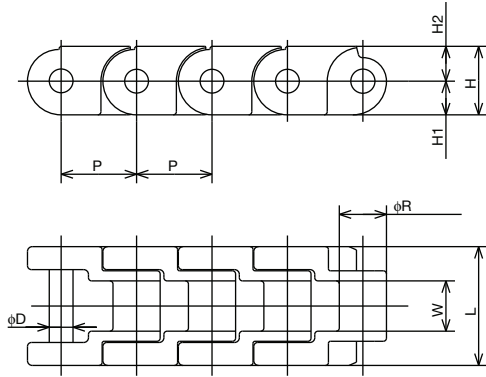

Single Strand Chain Plastic Pin

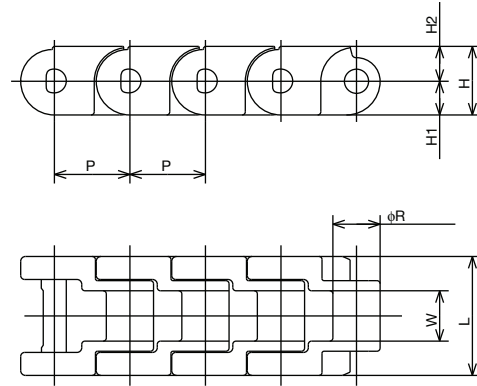

Double Strand Chain (RS60P-2) Stainless Steel Pin

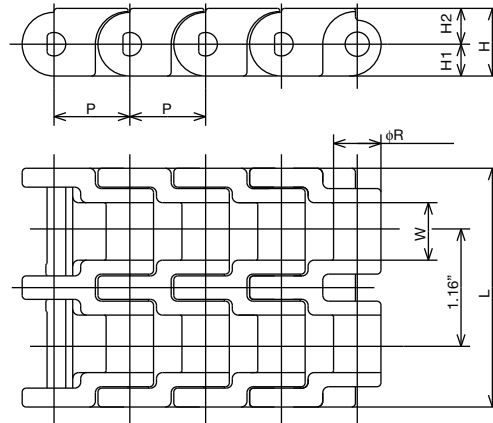

All dimensions in inches unless otherwise stated.

Chain Number	Pin Type	Pitch P	R	Width Between Inner Link Plates W	Link Plate			Pin		Approx. Weight (lbs./ft.)	Number of links per 10 feet
					Total Height H	Height H ₁	Height H ₂	Dia. D	Length L		
Single Strand											
RS35P	S	0.375	0.200	0.188	0.035	0.157	0.197	0.142	0.512	0.10	320
RS40P	S	0.500	0.313	0.313	0.500	0.236	0.264	0.157	0.787	0.24	240
RS50P	S	0.625	0.400	0.375	0.591	0.276	0.315	0.197	0.886	0.31	192
RS60P	S	0.750	0.469	0.500	0.681	0.335	0.346	0.236	1.181	0.48	160
RSP40P	P	0.500	0.313	0.313	0.500	0.236	0.264	na	0.787	0.17	240
RSP60P	P	0.750	0.469	0.500	0.681	0.335	0.346	na	1.181	0.35	160
Double Strand											
RS60P-2	S	0.750	0.469	0.570	0.669	0.315	0.354	na	2.362	1.00	160

Notes: "S" pin type represents stainless steel pin. "P" pin type represents plastic pin.

Maximum Allowable Loads (M.A.L.)

Chain Number	Standard Type M.A.L. (lbs.)	MW/MWB MWG/MWS Type M.A.L. (lbs.)	UMW Type M.A.L. (lbs.)	KV Type M.A.L. (lbs.)	E Type M.A.L. (lbs.)	Y Type M.A.L. (lbs.)
Single Strand						
RS35P	40	40	30	40	30	20
RS40P	100	100	65	100	75	55
RS50P	155	155	110	na	110	90
RS60P	200	200	140	200	140	110
RSP40P	na	55	na	na	na	na
RSP60P	na	130	na	na	na	na
Double Strand						
RS60P-2	na	285	200	na	na	na

Layout of Guide Rails and Sprocket RS35P-RS60P

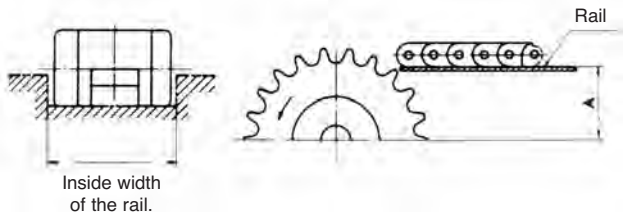

$$A = \left(\frac{PCD}{2} \right) - X \quad (\text{inches})$$

Where:

$$PCD = \text{Pitch Circle Diameter} = \frac{P}{\left(\sin \left(\frac{180^\circ}{N} \right) \right)} \quad (\text{inches})$$

P=Pitch=see specification tables.

N=Number of teeth on the sprocket.

X=0.137 (RS35P), 0.216 (RS40P)

0.255 (RS50P), 0.295 (RS60P-2)

0.314 (RS60P)

Double Pitch - Linear Movement

Plastic Chain

Section D

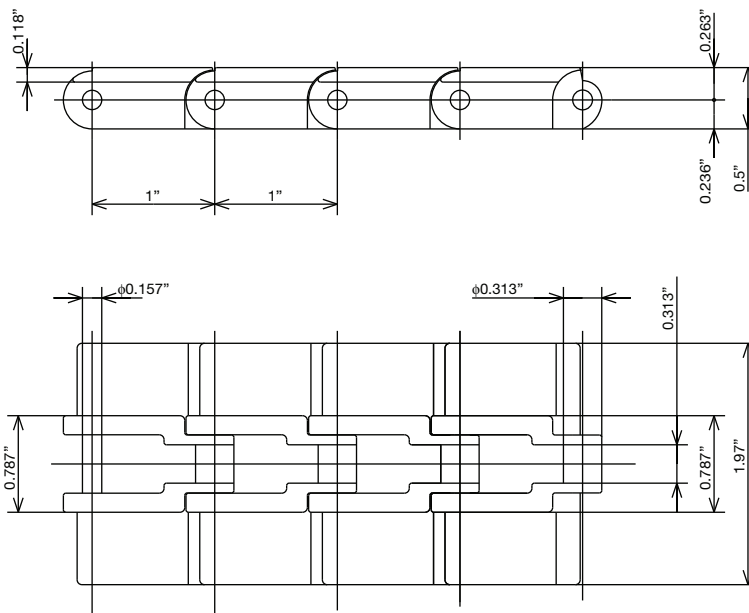
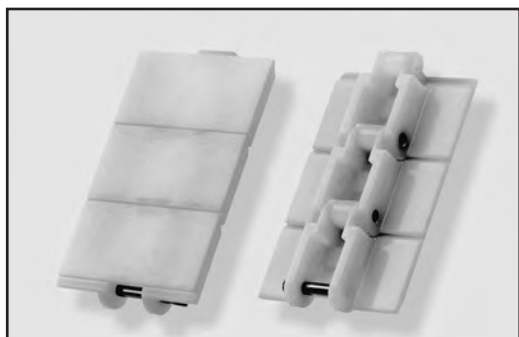

Layout of Guide Rails and Sprocket

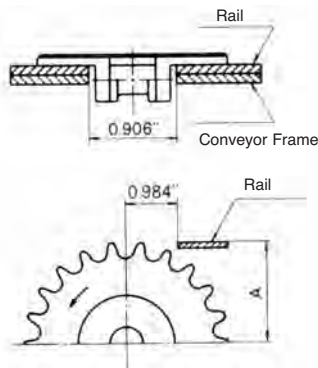

$$A = \left(\frac{PCD}{2} \right) + .157 \quad (\text{inches})$$

Chain Number	All types (ex UMW) Maximum Allowable Load (lbs.)	UMW Type Maximum Allowable Load (lbs.)	Approx. Weight (lbs./ft.)
RS2040P	100	65	0.281

RS Single Pitch - Curved Movement

Plastic Chain

Single Strand Chain



Double Strand Chain

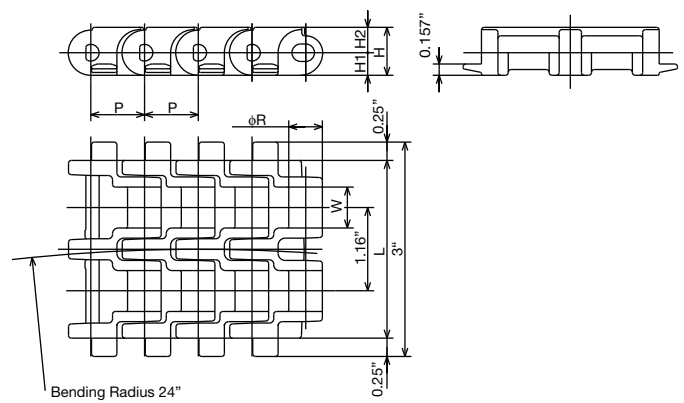
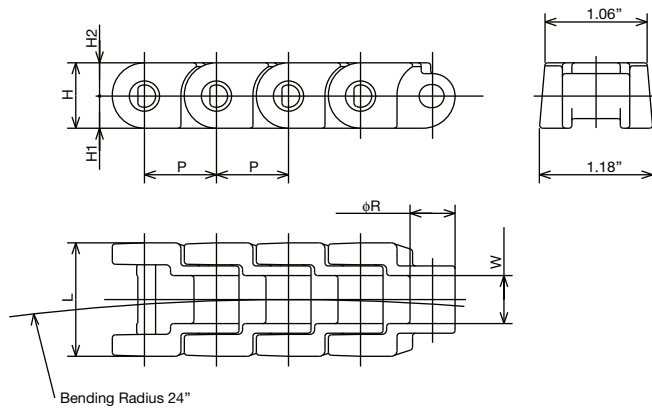
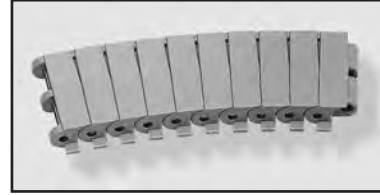

All dimensions in inches unless otherwise stated.

Chain Number	Pin Type	Pitch P	R	Width Between Inner Link Plates W	Link Plate			Pin Length L	All types (ex UMW) Maximum Allowable Load (lbs.)	UMW Type Maximum Allowable Load (lbs.)	Approx. Weight (lbs./ft.)
					Total Height H	Height H ₁	Height H ₂				
Single Strand											
RS60PU	S	0.750	0.469	0.500	0.681	0.335	0.346	1.181	185	130	0.48
RSP60PU	P	0.750	0.469	0.500	0.681	0.335	0.346	1.181	100	na	0.33
Double Strand											
RS60PU-2	S	0.750	0.469	0.570	0.669	0.315	0.354	2.480	220	175	1.00

Notes: "S" pin type represents stainless steel pin. "P" pin type represents plastic pin. Consult Tsubaki Technical Support for sprocket information.

Conveying Side

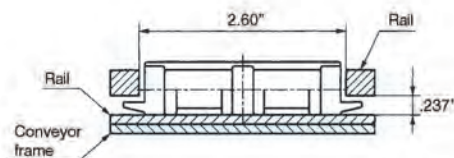

Return Side

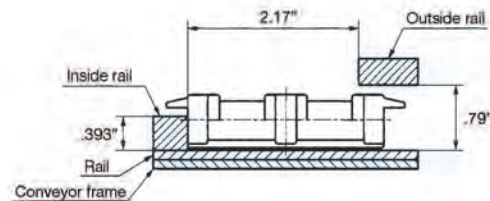

B. Plastic Top Chains

Tsubaki offers plastic top chain designs to meet your strength, speed and space requirements. Tsubaki top chain is ideal for continuous conveying applications such as bottling, canning and packaging of beverages, food, drugs, chemicals and for conveying machine parts. Plastic top chain is available in both linear and curved styles. Following is an outline of the types of plastic top chain available to suit many applications:

TTP-Linear Movement

Plastic Top Chain

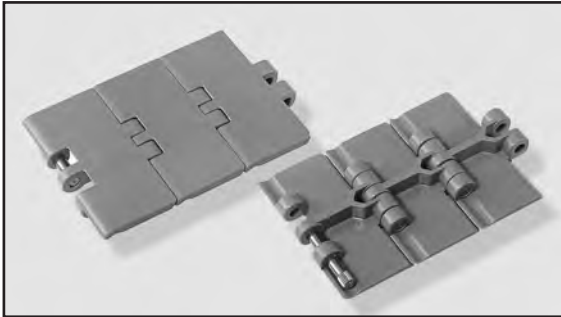

These chains are used in linear conveyors to transport or accumulate materials that could be easily scratched, such as bottles or cans. Set-ups may use one or more strands of chain. In TTP Top Chain, the individual top plates made of molded polyacetal are connected using type 304 (18/8) stainless steel pins. Due to its simple construction, the chain can be easily washed and cleaned.

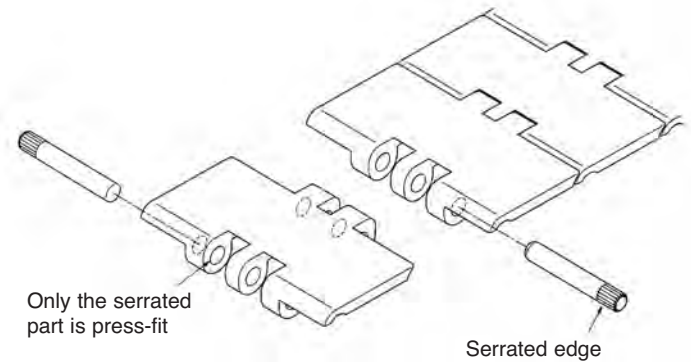

Stainless Steel Pin Chain Diagram

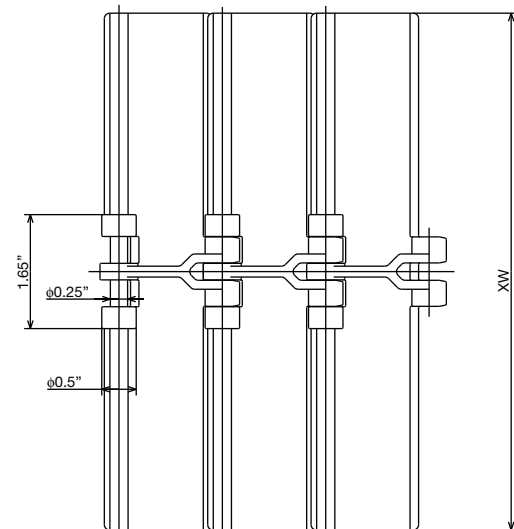
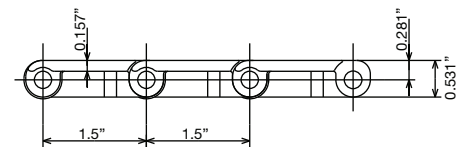

Chain Number	Pin Type	Top Plate Width XW	All types (ex UMW) Maximum Allowable Load (lbs.)	UMW type Maximum Allowable Load (lbs.)	Approximate Weight (lbs./ft.)
TTP635	S	2.50"	185	155	0.54
TTP635P	P	2.50"	185	130	0.37
TTP762	S	3.00"	185	155	0.60
TTP762P	P	3.00"	185	130	0.44
TTP826	S	3.25"	185	155	0.60
TTP826P	P	3.25"	185	130	0.44
TTP1016	S	4.00"	185	155	0.67
TTP1016P	P	4.00"	185	130	0.50
TTP1143	S	4.50"	185	155	0.67
TTP1143P	P	4.50"	185	130	0.54
TTP1270	S	5.00"	NA	155	0.74
TTP1270P	P	5.00"	NA	130	0.57
TTP1524	S	6.00"	NA	155	0.80
TTP1524P	P	6.00"	NA	130	0.64
TTP1651	S	6.50"	NA	155	0.87
TTP1651P	P	6.50"	NA	130	0.70
TTP1905	S	7.50"	NA	155	0.94
TTP1905P	P	7.50"	NA	130	0.80

Notes: "S" pin type represents stainless steel pin. "P" pin type represents plastic pin.

Layout of Guide Rails and Sprocket

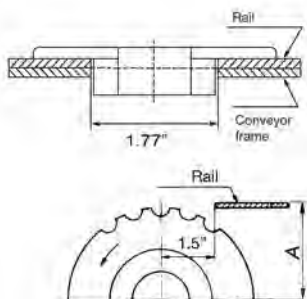

$$A = \left(\frac{PCD}{2} \right) + .157 \quad (\text{inches})$$

TP-Linear Movement

Plastic Top Chain

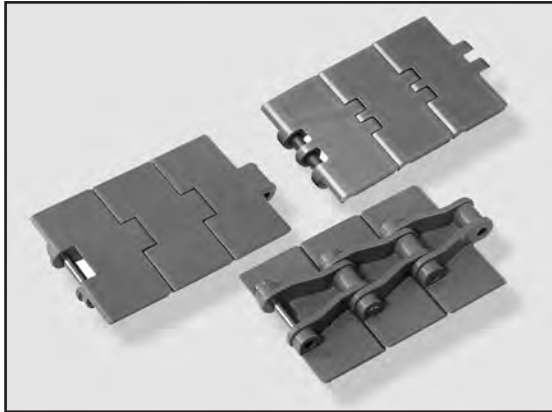

These chains are used for linear conveyance and consist of polyacetal resin top plates formed with each link and type 304 (18-8) stainless steel pins. The top plate is uniquely shaped to ensure high strength and maximum chain life. The TP Top Chains can be easily assembled and disassembled. There are two specifications of TP Top Chain: Type I and Type II. If you are developing a new application, consider Type II Chain. It offers higher wear resistance and a larger roller diameter than Type I.

Stainless Steel Pin Diagram

Plastic Pin Diagram

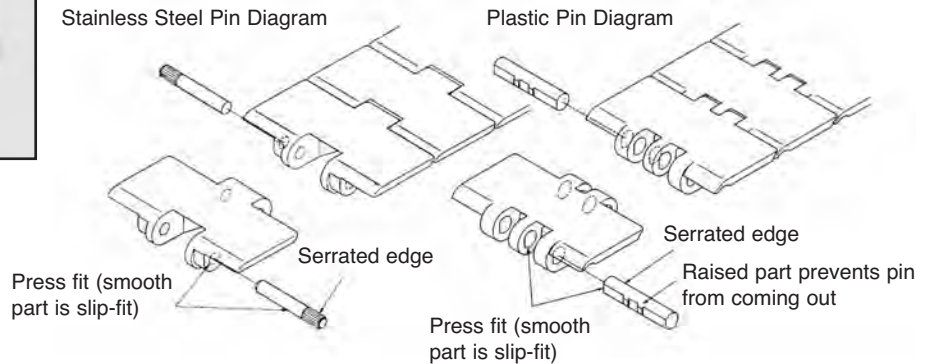

TP-Type I Stainless Steel Pin

TP-Type II Stainless Steel Pin

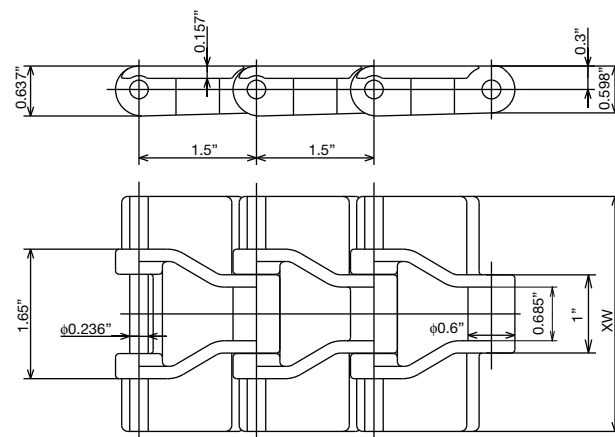
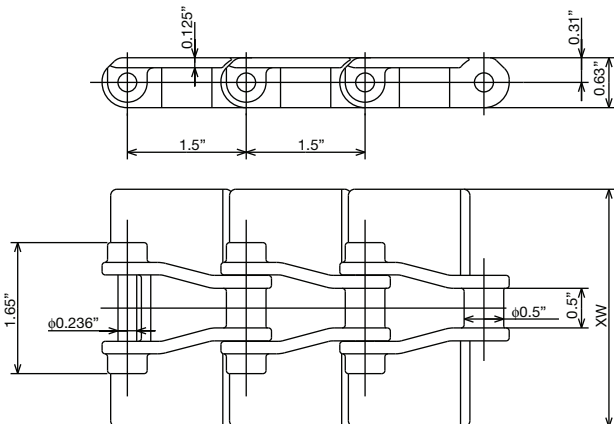

Chain Number	Pin Type	Top Plate Width XW	All types (ex UMW/KV) Maximum Allowable Load (lbs.)	UMW type Maximum Allowable Load (lbs.)	KV type Maximum Allowable Load (lbs.)	Approx. Weight (lbs./ft.)
TP762-I	S	3.00"	265	na	na	0.57
TP762-II	S	3.00"	265	na	na	0.57
TP826-I	S	3.25"	265	na	220	0.57
TP826-II	S	3.25"	265	na	220	0.57
TP826P-II	P	3.25"	220	185	na	0.50
TP1016-II	S	4.00"	265	na	na	0.70
TP1143-II	S	4.50"	265	na	na	0.74
TP1143P-II	P	4.50"	220	185	na	0.67
TP1270-II	S	5.00"	265	185	na	0.80

Notes: "S" pin type represents stainless steel pin. "P" pin type represents plastic pin.

Layout of Guide Rails and Sprocket

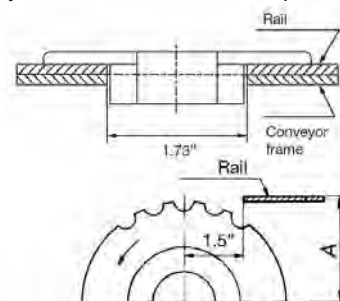

$$A = \left(\frac{PCD}{2} \right) + .197 \text{ (inches) TPI}$$

$$A = \left(\frac{PCD}{2} \right) + .157 \text{ (inches) TPII}$$

TPH-Linear Movement Plastic Top Chain

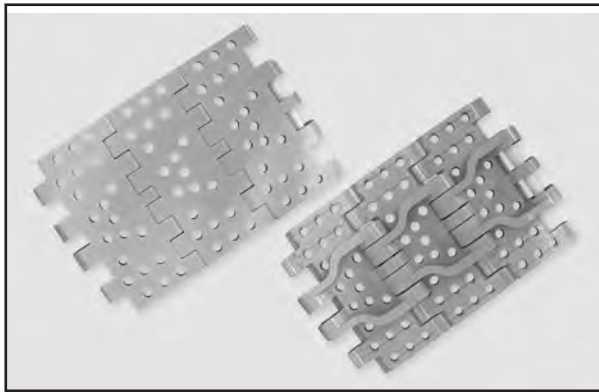

TPH: Top plate contains drainage holes – perfect for conveying PET bottles through a rinser. The edges of the top of this chain are less beveled compared to other table top chains and thus hold the bottles more stable as they travel along the conveyor.

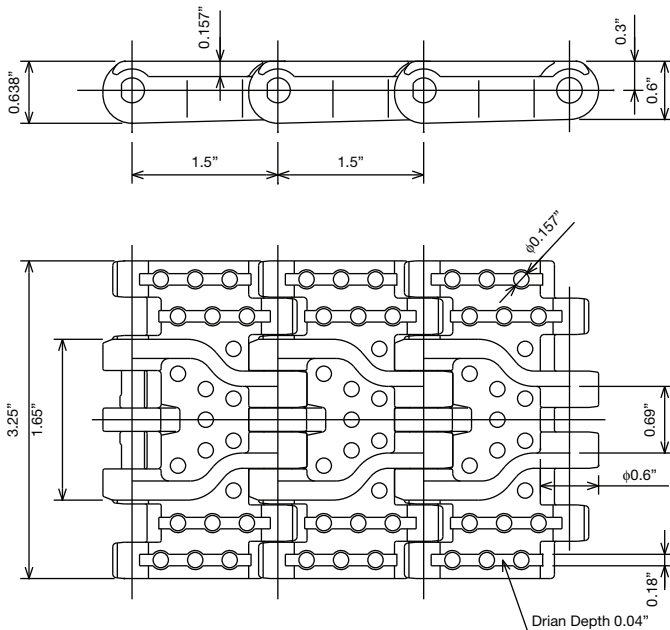
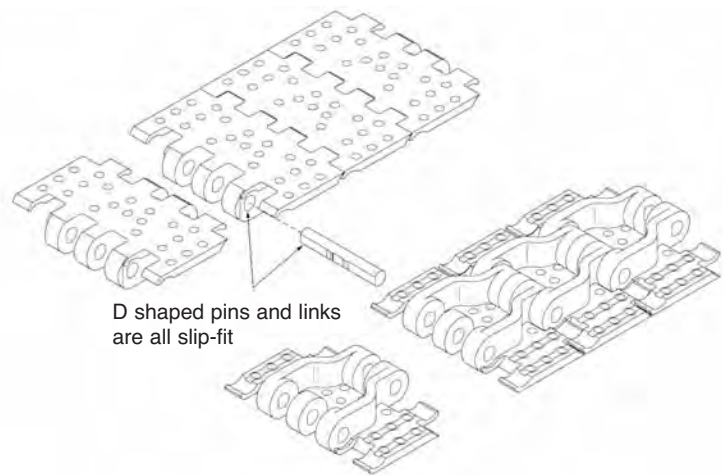

Layout of Guide Rails and Sprocket

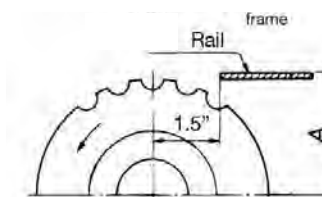
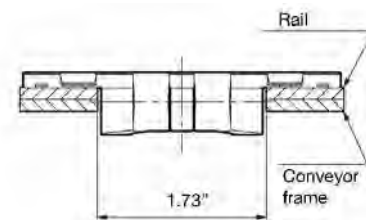

$$A = \left(\frac{PCD}{2} \right) + .157 \text{ (inches)}$$

Chain Number	Pin Type	All types (ex UMW) Maximum Allowable Load (lbs.)	UMW type Maximum Allowable Load (lbs.)	Approx. Weight (lbs./ft.)
TPH830	S	265	185	0.67
TPH830P	P	175	130	0.50

Notes: "S" pin type represents stainless steel pin. "P" pin type represents plastic pin.

Section D

MTP-Linear Movement Plastic Top Chain

MTP-826T

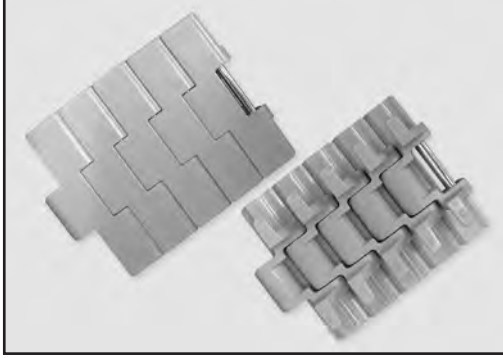

These chains allow for the smooth transfer of conveyed goods from one conveyor to another. The MTP chains have a narrower pitch compared to TP or TTP; and so there is a smaller gap between the end of one conveyor and the start of the next conveyor. MTP chain is also available in a low noise design (part numbers MTP826SNT and MTP826PSNT). The small pitch (half the pitch of conventional top chain), multi-hinge structure and minimization of chordal action when the sprocket engages with the chain allows for further stability of conveyed items. The hold-down tab prevents the chain from floating on ascending and descending conveyors (eg. vacuum conveyor). By further supporting the chain's return side tab with a rail, the slat's upper surface will be protected against scratching and will be kept clean.

MTP-826SNT

MTP-826PSNT

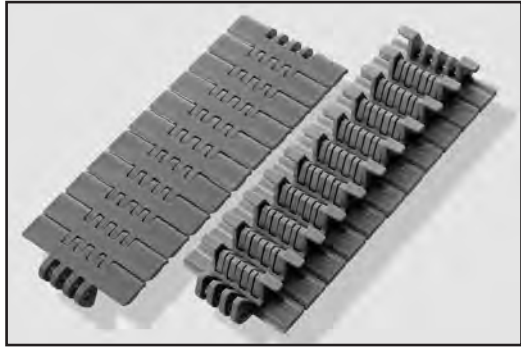

Layout of Guide Rails and Sprocket
Conveyor Side

Drive Side

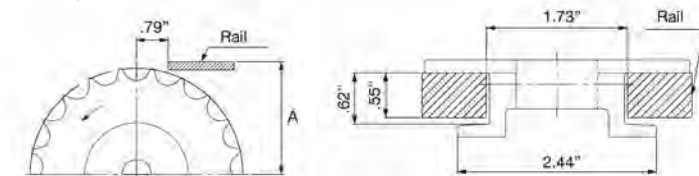

Return Side $A = \left(\frac{PCD}{2} \right) + .157$ Driven Side

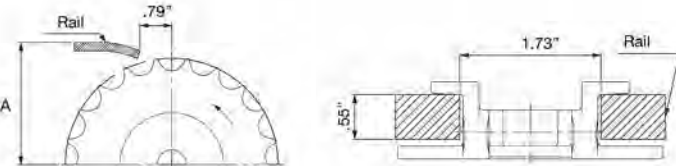

Chain Number	Pin Type	All types (ex UMW) Maximum Allowable Load (lbs.)	UMW type Maximum Allowable Load (lbs.)	Approx. Weight (lbs./ft.)
MTP826T	S	265	185	0.94
MTP826SNT	S	265	185	0.94
MTP826P-SNT	P	175	130	0.74

Notes: "S" pin type represents stainless steel pin.
"P" pin type represents plastic pin.

MTP-826T

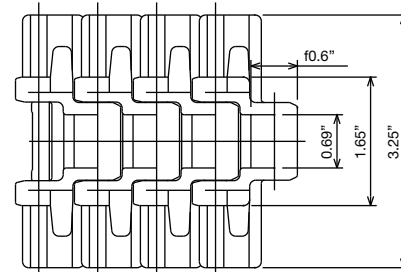
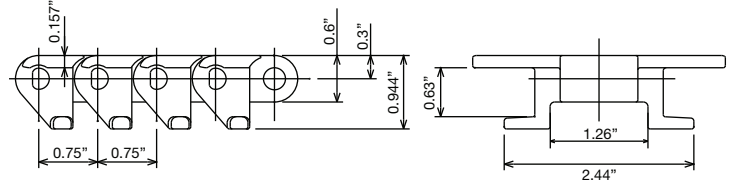

MTP-826SNT - MTP-826PSNT

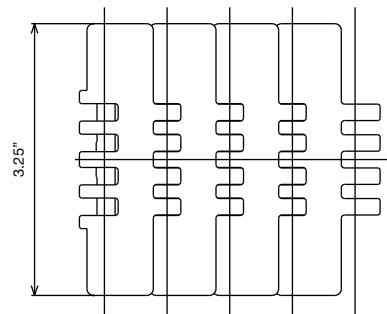
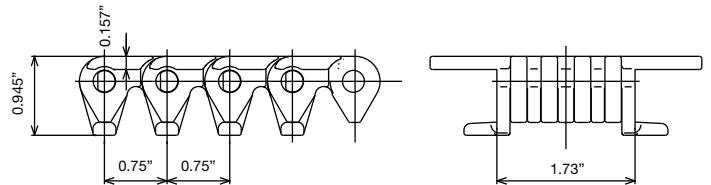

TN-Linear Movement

Plastic Top Chain

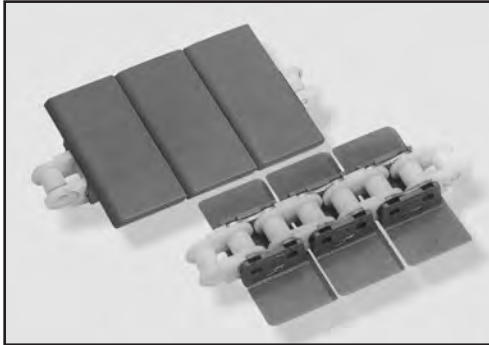

This linear conveyance chain consists of engineered plastic top plates snapped onto outer links of RS60 Roller Chain (chain pitch: 3/4" with non-riveted pin ends). It is easy to install or exchange top plates in this chain. When snap-on top plates of two or more separate chains are guided by the liners, it is possible to move conveyed objects across chains. The chain is available in 5 types – carbon steel, nickel plated carbon steel, nickel plated (lube free) Lambda, type 304 (18-8) Stainless steel and Poly-Steel – to meet any application requirement. All chains use type 304 stainless steel pins.

Consider the following when selecting and handling TN type chain:

- (1) Snap-on top plates will not separate from the base chain under normal use. Excessive loads may cause snap-on top plates to separate.
- (2) An idler pulley should not be used for this chain.
- (3) The back portion of the top plate rises slightly above the level of the conveying surface in the area where the chain engages with the sprocket. This should be considered when designing a system.

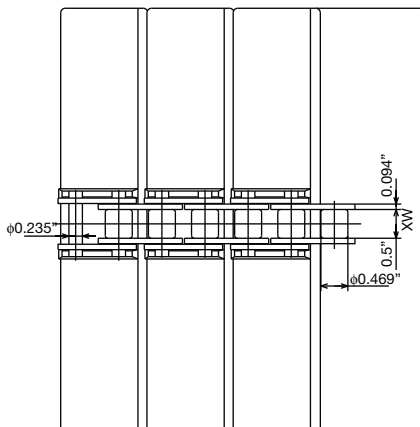
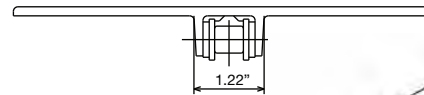
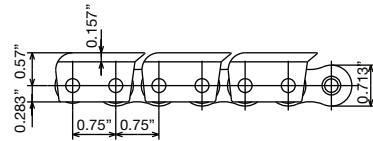

Layout of Guide Rails and Sprocket

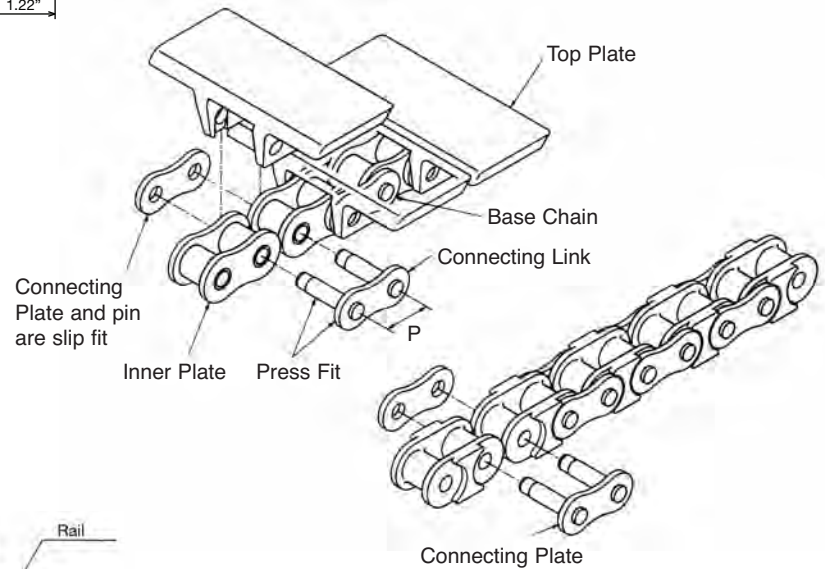
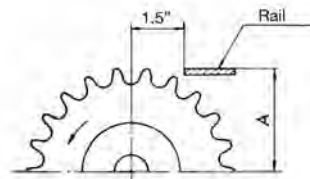
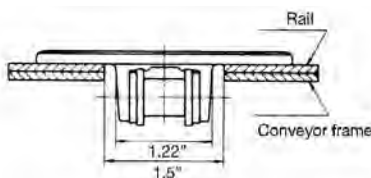

$$A = \left(\frac{PCD}{2} \right) + .433 \text{ (inches)}$$

Carbon Steel Chain Number	(NP) Nickel Plated Carbon Steel Chain Number	(NP-L) Nickel Plated Lambda Chain Number	(SS) Stainless Steel Chain	(PC) Poly-Steel Chain Number	Top Plate Width XW	Approximate Weight (lbs./ft.)
TN826	TN826NP	TN826NP-LAMBDA	TN826SS	TN826PC	3.25"	1.41 (1.00 PC)
TN1016	TN1016NP	TN1016NP-LAMBDA	TN1016SS	-	4.00"	1.47
TN1143	TN1143NP	TN1143NP-LAMBDA	TN1143SS	-	4.50"	1.54
TN1270	TN1270NP	TN1270NP-LAMBDA	TN1270SS	-	5.00"	1.61
TN1905	TN1905NP	TN1905NP-LAMBDA	TN1905SS	-	7.50"	1.88

Note: Maximum Allowable loads are as follows: Carbon Steel, Nickel Plated (NP) and Nickel Plated Lambda (NP-L): 1,410 lbs. Stainless Steel (SS): 230 lbs., Poly Steel (PC): 200 lbs.

Section D

TTUP-Curved Movement

Plastic Top Chain



One or more strands of TTUP Top Chains are used for curved conveying or accumulating objects that are easily scratched, for example, bottles, cans, and finely machined parts. TTUP Top Chain is based on engineered plastic Type II TP Top Chain, but it has extra side-flexing capability. It has a minimum radius of 24" and can curve around corners. This is accomplished with tapered knuckles. There are no hold-down tabs on the links of TTUP Top Chain, so it can be more easily detached from the guide rails.

Layout of Guide Rails and Sprocket

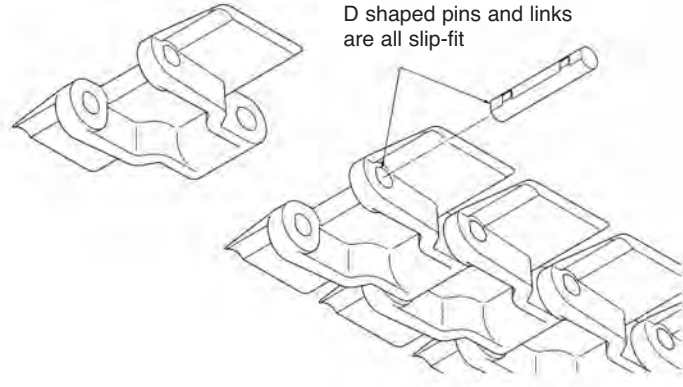
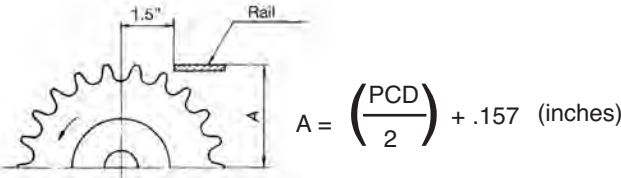

Stainless Steel Pin

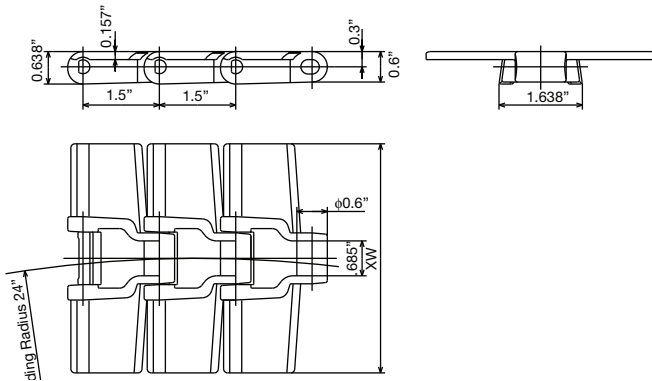

Plastic Pin

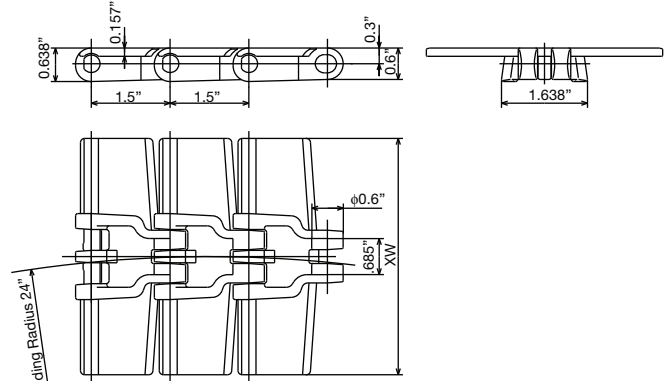

All dimensions in inches unless otherwise stated.

Chain Number	Pin Type	Top Plate Width XW	Minimum Radius R	All types (ex UMW/KV) Maximum Allowable Load (lbs.)	UMW type Maximum Allowable Load (lbs.)	KV type Maximum Allowable Load (lbs.)	Approx. Weight (lbs./ft.)
TTUP826	S	3.25	24.00	240	175	220	0.67
TTUP826P	P	3.25	24.00	240	175	na	0.47
TTUP1143	S	4.50	24.00	240	175	na	0.74
TTUP1143P	P	4.50	24.00	200	135	na	0.54
TTUP1905	S	7.50	24.00	200	135	na	1.07

Notes: "S" pin type represents stainless steel pin. "P" pin type represents plastic pin.

TPU-Curved Movement

Plastic Top Chain

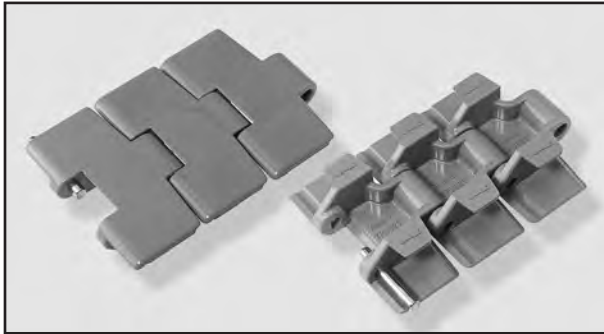

This top chain is used for curved conveyance of such items as bottles and cans. It is used in many of the same applications as TTUP Top Chain. TPU Top Chain has side-flexing capability with a minimum radius (R) of 20" and is equipped with hold-down tabs on the top plates.

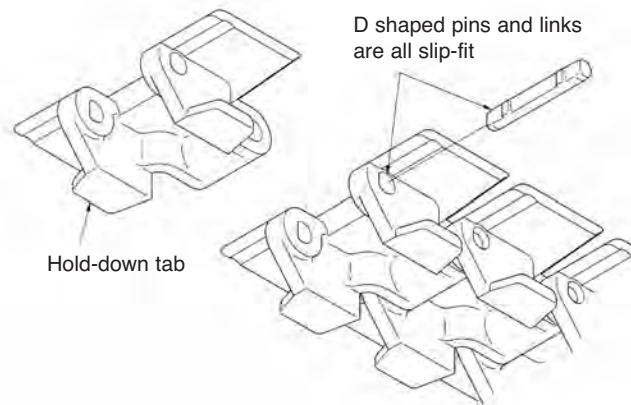

Layout of Guide Rails and Sprocket

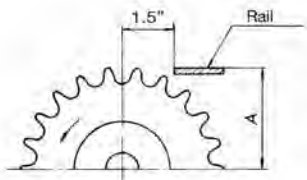

$$A = \left(\frac{PCD}{2} \right) + .157 \text{ (inches)}$$

Stainless Steel Pin

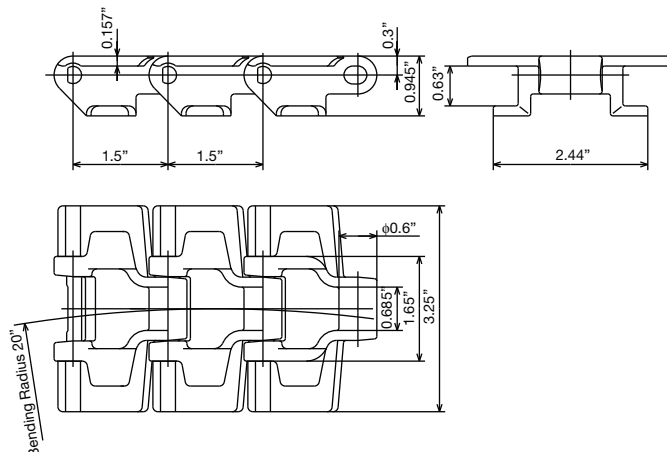

Plastic Pin

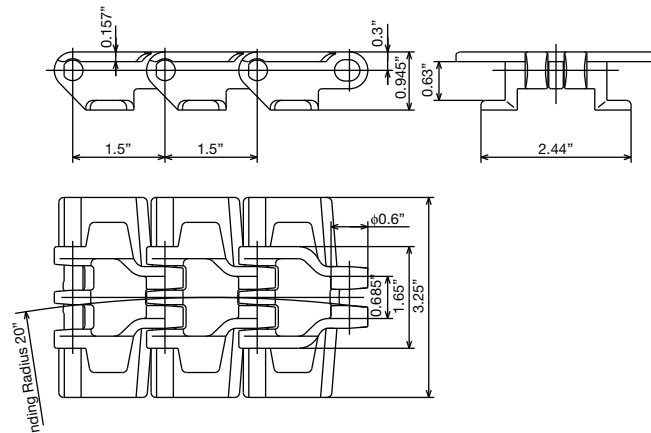

Chain Number	Pin Type	Minimum Radius R	All types (ex UMW/KV) Maximum Allowable Load (lbs.)	UMW type Maximum Allowable Load (lbs.)	KV type Maximum Allowable Load (lbs.)	Approx. Weight (lbs./ft.)
TPU826	S	20.00"	220	150	220	0.67
TPU826P	P	20.00"	200	135	na	0.54

Notes: "S" pin type represents stainless steel pin. "P" pin type represents plastic pin.

Section D

MTPU-Curved Movement

Plastic Top Chain

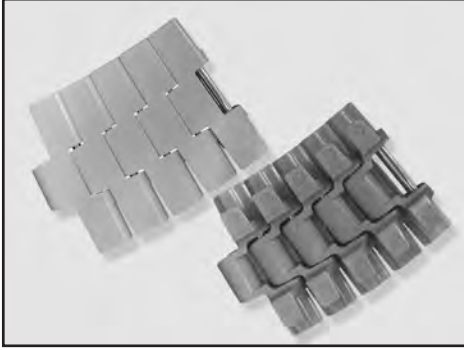

These chains are used for curved conveyance. They allow for the smooth transfer of conveyed goods from one conveyor to another. The MTPU chains have a narrower pitch compared to TPU or TTPU; and so there is a smaller gap between the end of one conveyor and the start of the next conveyor. These chains use stainless steel pins.

Layout of Guide Rails and Sprocket Drive Side

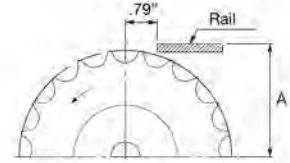

Driven Side

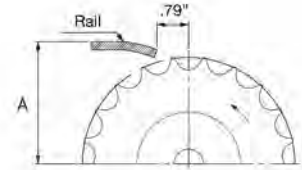

$$A = \left(\frac{\text{PCD}}{2} \right) + .157 \text{ (inches)}$$

Conveyor Side

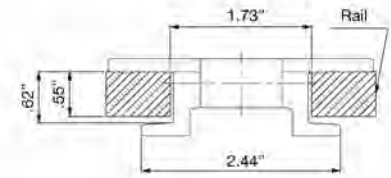

Return Side

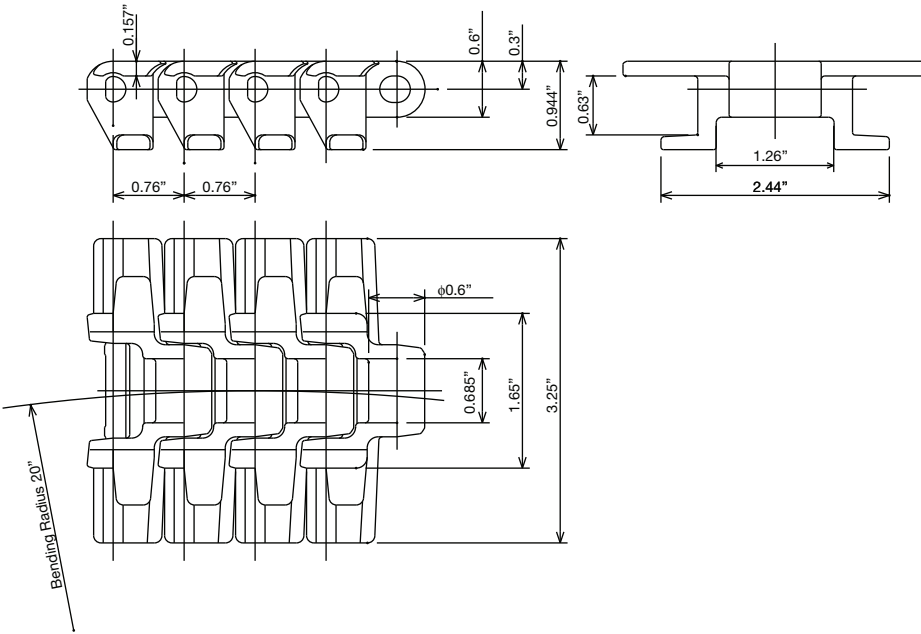
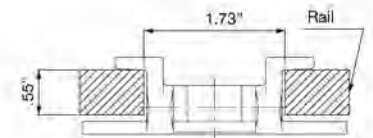

Chain Number	All types (ex UMW) Maximum Allowable Load (lbs.)	UMW type Maximum Allowable Load (lbs.)	Approximate Weight (lbs./ft.)
MTPU826T	220	150	0.94

TPSR-Curved Movement

Plastic Top Chain

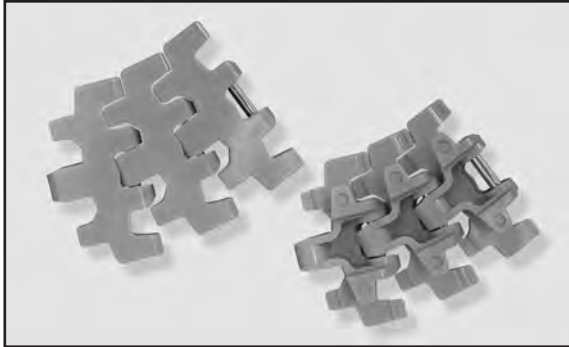

These chains are used for curved conveyance and have a smaller bending radius that provides more flexibility for the layout of conveyor lines. Stainless steel pins are used on this chain.

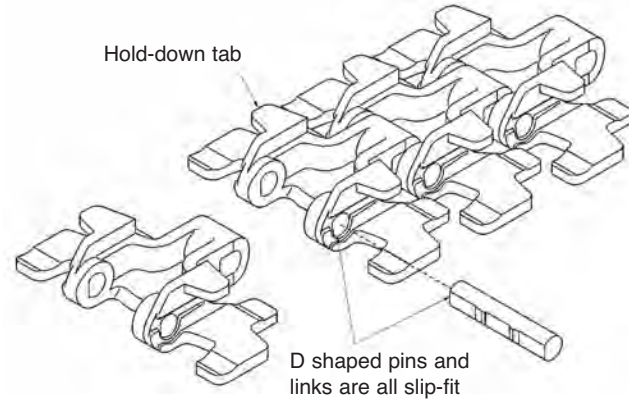

Section D

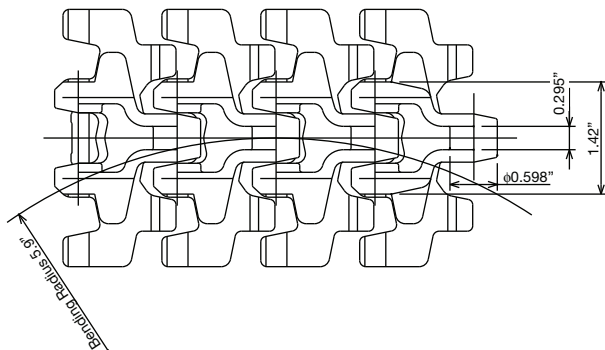
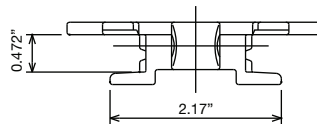
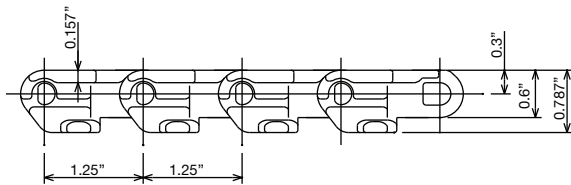
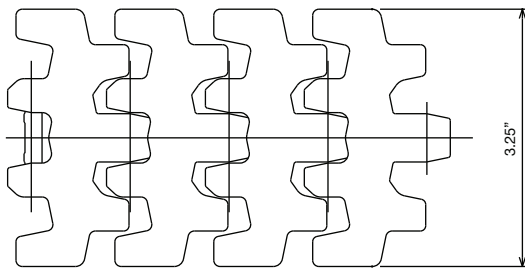

Chain Number	Minimum Radius R	All types (ex. UMW) Maximum Allowable Load (lbs.)	UMW type Maximum Allowable Load (lbs.)	Approx. Weight (lbs./ft.)
TPSR826T	5.90"	220	150	0.60

Consult Tsubaki Technical Support for sprocket information.

TNU-Curved Movement

Plastic Top Chain

This curved conveyance chain consists of engineered plastic top plates snapped onto outer links of RS60 Roller Chain (chain pitch: 3/4" with non-riveted pin ends). It is easy to install or exchange top plates in this chain. When snap-on top plates of two or more separate chains are guided by the liners, it is possible to move conveyed objects across chains.

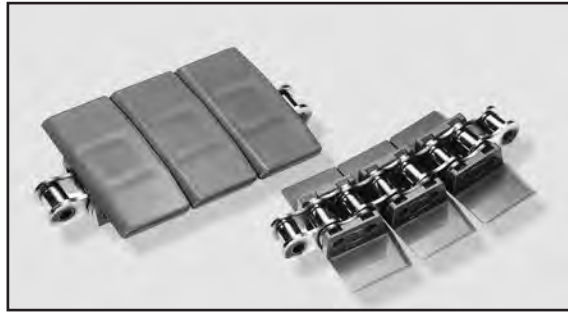

- The chain is available in 3 types – carbon steel, nickel plated carbon steel, and type 304 (18-8) Stainless steel – to meet any application requirement. All chains use type 304 stainless steel pins. Consider the following when selecting and handling TN type chain:
- (1) Snap-on top plates will not separate from the base chain under normal use. Excessive loads may cause snap-on top plates to separate.
 - (2) An idler pulley should not be used for this chain.
 - (3) The back portion of the top plate rises slightly above the level of the conveying surface in the area where the chain engages with the sprocket. This should be considered when designing a system.

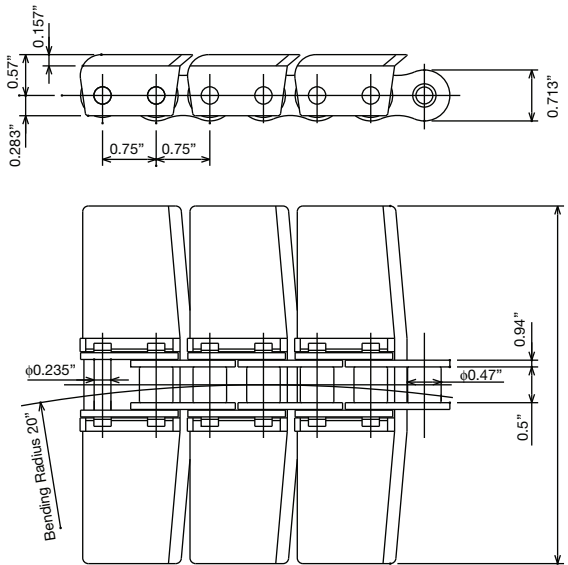
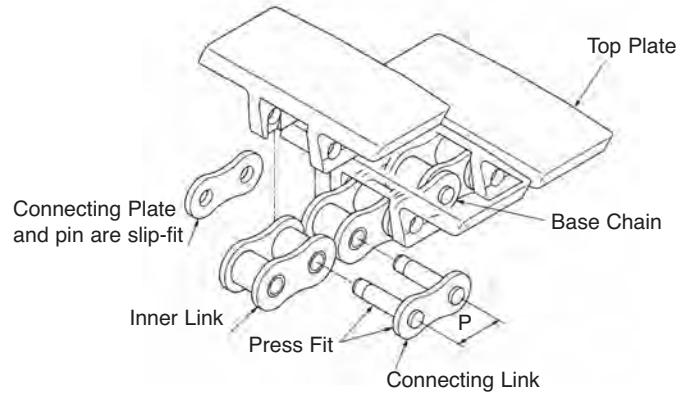

Layout of Guide Rails and Sprocket

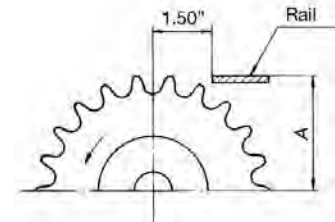

$$A = \left(\frac{PCD}{2} \right) + .433 \text{ (inches)}$$

All dimensions in inches unless otherwise stated.

Carbon Steel Chain Number	(NP) Nickel Plated Carbon Steel Chain Number	(AS) Stainless Steel Chain Number	Top Plate Width XW	Minimum Radius R	Approximate Weight (lbs./ft.)
TNU826	TNU826NP	TNU826AS	3.25	20.00	1.47
TNU1143	TNU1143NP	TNU1143AS	4.50	20.00	1.54
TNU1270	TNU1270NP	TNU1270AS	5.00	20.00	1.68

Notes: Maximum allowable loads are as follows: Carbon Steel and Nickel Plated (NP): 900 lbs., Stainless Steel (AS): 175 lbs.

C. Plastic Snap Cover Chain

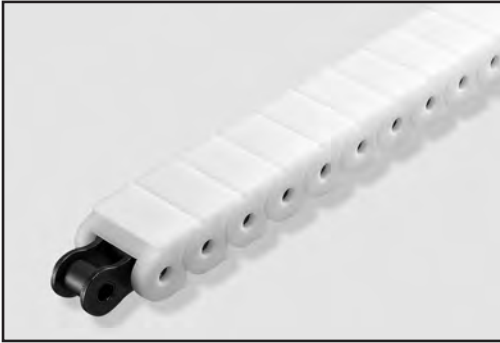

Tsubaki Snap Cover Chain is standard roller chain with an engineering plastic cover attached to each link. It has the same allowable tensile strength as steel chain while allowing (even fragile) materials and products to be placed directly onto the chain without concern of damage. Snap Cover Chain can be used for heavy load and long conveyor line applications previously not possible with standard RS series plastic chain. For the user, this means lower conveying costs and enhanced productivity. The innovative snap cover design features engineering thermoplastic covers that fit together seamlessly and securely over the pins on each link of the steel base chain. (Cotter pins/spring clips are not used. The “legs” of the plastic snap cover are used to hold down the connecting link plate and to prevent it from becoming loose).

The flexibility of the design means that the base chain can be either Tsubaki's standard carbon steel roller chain or, for "clean" applications where lubrication is difficult or not permitted, Tsubaki's lube-free Lambda series. Another option is a stainless steel (SS) base chain for operating environments where corrosion could be a problem. There are two options in the choice of plastic covers: white polyacetal (standard/general usage) and black electro-conductive (preventing static/dust build-up). Snap cover chain is available in six pitch sizes, and is designed for use at running speeds up to 200 ft./min in the temperature range from -14° F and +176° F. In common with all Tsubaki chain products, the operation, assembly, disassembly and recycling of Snap Cover Chain is simple and efficient. The resin cover is simply removed using a screwdriver and the connecting link pins and plates are all loose fitting.

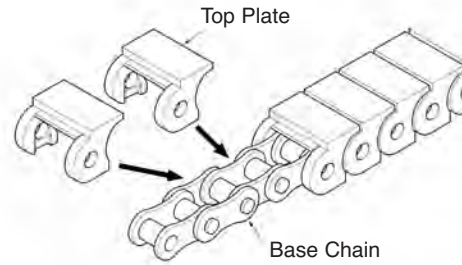
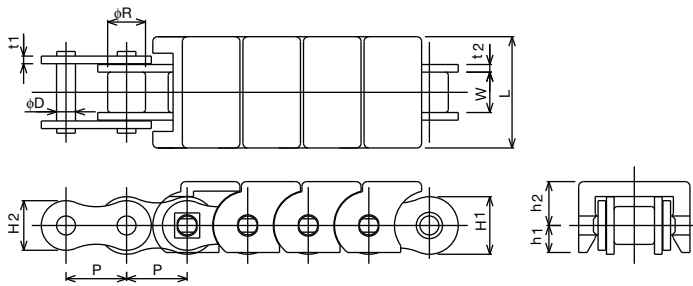

All dimensions in inches unless otherwise stated.

Carbon Steel Chain Number	Lambda Chain Number	(SS) Stainless Steel Chain Number	Pitch P	Roller Dia. R	Width Between Inner Link Plates W	Link Plate				Pin Dia. D
						Thickness t ₁	Thickness t ₂	Height H ₁	Height H ₂	
*RF06B-SC	-	*RF06BSS-SC	0.375	0.250	0.225	0.039	0.050	0.323	0.323	0.129
RS40-SC	RSC40-LAMBDA-SC	RS40SS-SC	0.500	0.312	0.313	0.059	0.059	0.472	0.409	0.156
RS50-SC	RSC50-LAMBDA-SC	RS50SS-SC	0.625	0.400	0.375	0.079	0.079	0.591	0.512	0.200
RS60-SC	RSC60-LAMBDA-SC	RS60SS-SC	0.750	0.469	0.500	0.094	0.094	0.713	0.614	0.235
RS80-SC	RSC80-LAMBDA-SC	RS80SS-SC	1.000	0.629	0.625	0.126	0.126	0.949	0.819	0.313
RS100-SC	RSC100-LAMBDA-SC	RS100SS-SC	1.250	0.750	0.750	0.157	0.157	1.185	1.024	0.376

Carbon Steel Chain Number	Lambda Chain Number	(SS) Stainless Steel Chain Number	Plastic Cover			(Carbon Steel and Lambda) Maximum Allowable Load (lbs.)	(Stainless Steel) Maximum Allowable Load (lbs.)	Approx. Weight (lbs./ft.)	Number of Links per 10 Feet
			Height h ₁	Height h ₂	Length L				
*RF06B-SC	-	*RF06BSS-SC	0.173	0.291	0.689	330	60	3.2	320
RS40-SC	RSC40-LAMBDA-SC	RS40SS-SC	0.236	0.374	0.925	600	100	5.8	240
RS50-SC	RSC50-LAMBDA-SC	RS50SS-SC	0.295	0.457	1.142	970	155	9.5	192
RS60-SC	RSC60-LAMBDA-SC	RS60SS-SC	0.335	0.543	1.378	1,410	230	13.8	160
RS80-SC	RSC80-LAMBDA-SC	RS80SS-SC	0.453	0.709	1.634	2,405	400	23.6	120
RS100-SC	RSC100-LAMBDA-SC	RS100SS-SC	0.579	0.839	1.909	3,845	575	37.7	96

* RF06B has a flat shaped link plate. This chain uses standard ANSI sprockets.

Section D

D. Plastic Roller Table Chain

Roller Table Chain lets you convey and accumulate groups of small, separate objects, such as bottles, boxes, or cans. With Roller Table Chain, pallets are usually not used - the conveyed materials are usually placed directly on engineered plastic rollers.

Roller Table Chain is constructed from two strands of chains, which are connected with stay-pins and engineered plastic rollers that rotate freely. Conveyed objects are placed directly on the engineered plastic rollers. Conveyed goods are accumulated on the Roller Table Chain with low friction. The engineered plastic rollers reduce line pressure during accumulation, protecting the conveyed items from damage; and ensuring smooth transfers from line to line. The Roller Table Chains are available in a variety of designs and are easy to assemble and disassemble. There are two types available: ST-type and RT-type.



“ST” Roller Table Chain

ST-type has special inverted attachments that cover the upper side of the chain. These attachments are level with the engineered plastic rollers, which permits low resistance as conveyed objects move across the chain and onto the engineered plastic rollers. ST-type uses a base chain that is made of type 304 stainless steel or nickel-plated carbon steel.

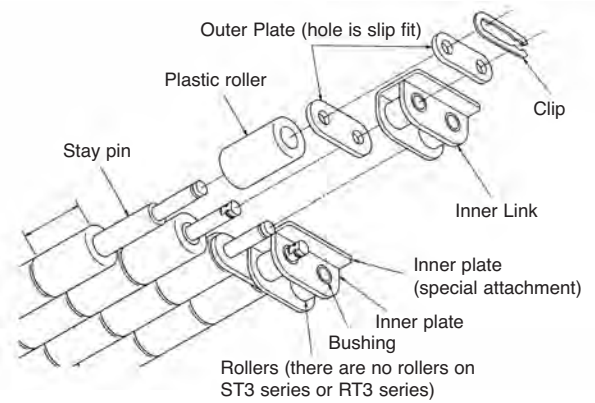
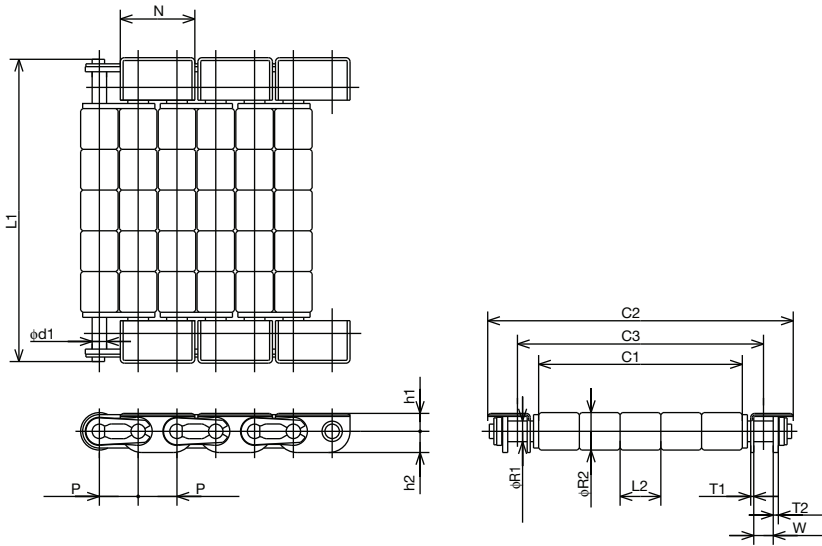

(SS) Stainless Steel Chain Number	(NP) Nickel Plated Carbon Steel Chain Number	Pitch P	Roller Dia. R ₁	Width Between Roller Link Plates W	Link Plate		Pin		Plastic Roller		Effective Width C ₁	Overall Width C ₂	Center Distance Between Chains C ₃	Attachment Specifications			Maximum Allowable Load (lbs./ft.)	Approx. Weight (lbs./ft.)
					Height h ₂	Thickness T ₂	Dia. d ₁	Length L ₁	Dia. R ₂	Length L ₂				Height h ₁	Width N	Thickness T ₁		
ST305SS	-	0.375	*0.200	0.188	0.205	0.049	0.139	2.921	0.362	0.394	1.969	2.953	2.378	0.173	0.720	0.030	10	1.17
ST310SS	-	0.375	*0.200	0.188	0.205	0.049	0.139	4.890	0.362	0.394	3.937	4.921	4.346	0.173	0.720	0.030	10	1.80
ST315SS	-	0.375	*0.200	0.188	0.205	0.049	0.139	6.858	0.362	0.394	5.906	6.890	6.315	0.173	0.720	0.030	10	2.42
ST320SS	-	0.375	*0.200	0.188	0.205	0.049	0.139	8.827	0.362	0.394	7.874	8.858	8.283	0.173	0.720	0.030	10	3.04
ST404SS	ST404NP	0.500	0.313	0.313	0.276	0.059	0.154	5.339	0.472	0.984	3.984	5.433	4.551	0.224	0.961	0.047	50	2.97
ST406SS	ST406NP	0.500	0.313	0.313	0.276	0.059	0.154	7.307	0.472	0.984	5.953	7.402	6.520	0.224	0.961	0.047	50	3.88
ST408SS	ST408NP	0.500	0.313	0.313	0.276	0.059	0.154	9.276	0.472	0.984	7.921	9.370	8.488	0.224	0.961	0.047	50	4.79
ST410SS	ST410NP	0.500	0.313	0.313	0.276	0.059	0.154	11.244	0.472	0.984	9.890	11.339	10.457	0.224	0.961	0.047	50	5.70
ST412SS	ST412NP	0.500	0.313	0.313	0.276	0.059	0.154	13.213	0.472	0.984	11.858	13.307	12.425	0.224	0.961	0.047	50	6.60
ST414SS	ST414NP	0.500	0.313	0.313	0.276	0.059	0.154	15.181	0.472	0.984	13.827	15.276	14.393	0.224	0.961	0.047	50	7.51
ST416SS	ST416NP	0.500	0.313	0.313	0.276	0.059	0.154	17.150	0.472	0.984	15.795	17.244	16.362	0.224	0.961	0.047	50	8.41
ST504SS	ST504NP	0.625	0.400	0.375	0.335	0.079	0.196	5.622	0.591	0.984	3.984	5.717	4.685	0.280	1.201	0.059	70	4.14
ST506SS	ST506NP	0.625	0.400	0.375	0.335	0.079	0.196	7.591	0.591	0.984	5.953	7.658	6.654	0.280	1.201	0.059	70	5.43
ST508SS	ST508NP	0.625	0.400	0.375	0.335	0.079	0.196	9.559	0.591	0.984	7.921	9.654	8.622	0.280	1.201	0.059	70	6.64
ST510SS	ST510NP	0.625	0.400	0.375	0.335	0.079	0.196	11.528	0.591	0.984	9.890	11.622	10.591	0.280	1.201	0.059	70	7.89
ST512SS	ST512NP	0.625	0.400	0.375	0.335	0.079	0.196	13.496	0.591	0.984	11.858	13.591	12.559	0.280	1.201	0.059	70	9.14
ST514SS	ST514NP	0.625	0.400	0.375	0.335	0.079	0.196	15.465	0.591	0.984	13.827	15.559	14.528	0.280	1.201	0.059	70	10.39
ST516SS	ST516NP	0.625	0.400	0.375	0.335	0.079	0.196	17.433	0.591	0.984	15.795	17.528	16.496	0.280	1.201	0.059	70	11.63
ST518SS	ST518NP	0.625	0.400	0.375	0.335	0.079	0.196	19.402	0.591	0.984	17.764	19.496	18.465	0.280	1.201	0.059	70	12.89
ST520SS	ST520NP	0.625	0.400	0.375	0.335	0.079	0.196	21.370	0.591	0.984	19.732	21.465	20.433	0.280	1.201	0.059	70	14.14
ST522SS	ST522NP	0.625	0.400	0.375	0.335	0.079	0.196	23.339	0.591	0.984	21.701	23.433	22.402	0.280	1.201	0.059	70	15.39
ST524SS	ST524NP	0.625	0.400	0.375	0.335	0.079	0.196	25.307	0.591	0.984	23.669	25.402	24.370	0.280	1.201	0.059	70	16.64

* The base chain for ST305SS, ST310SS, ST315SS and ST320SS is rollerless. The value shown is for the bushing diameter. This chain uses standard ANSI sprockets.

'RT' Roller Table Chain

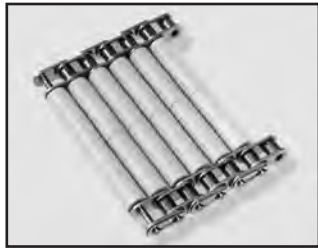

RT-type does not have special attachments covering the chain. Therefore, side guides are required to prevent smaller conveyed objects from crossing the chain part of the assembly. RT type has a wider plastic roller width than the ST type and it can be used for the transfer of objects of large widths such as shipping cartons and pallets. Line pressure is noticeably reduced during accumulation because of the low roll-friction coefficient of the plastic rollers. This low roll-friction coefficient protects the conveyed goods from damage and enables smooth divergence and confluence of the conveyor. RT-type uses a base chain that is made of stainless steel only.

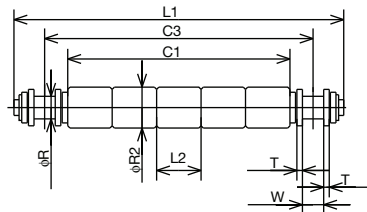
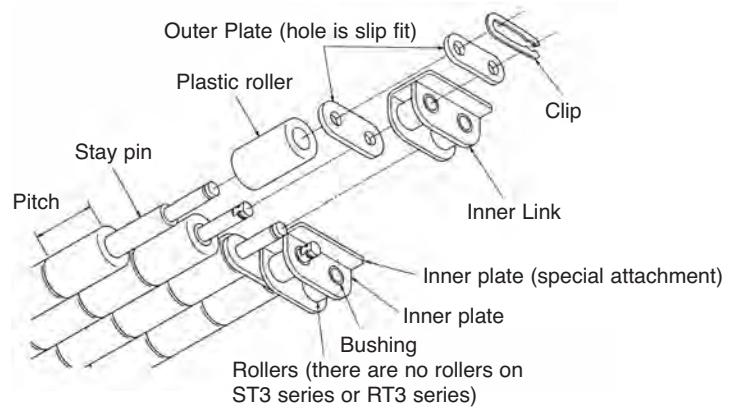
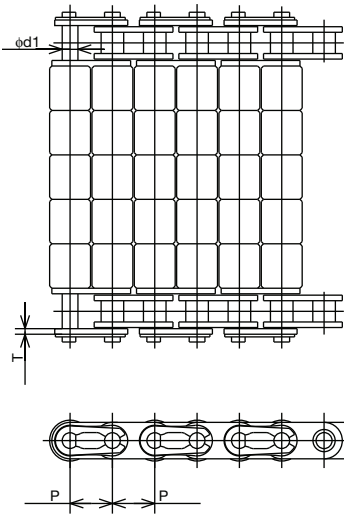

All dimensions in inches unless otherwise stated.

(SS) Stainless Steel Chain Number	Pitch P	Roller Dia. R ₁	Width Between Roller Plates W	Link Plate		Pin		Plastic Roller		Effective Width C ₁	Center Distance Between Chains C ₃	Maximum Allowable Load (lbs./ft ²)	Approx. Weight (lbs./ft.)
				Height H	Thickness T	Dia. d ₁	Length L ₁	Dia. R ₂	Length L ₂				
RT305SS	0.375	*0.200	0.188	0.323	0.049	0.139	2.920	0.362	0.394	1.988	2.378	10	1.13
RT310SS	0.375	*0.200	0.188	0.323	0.049	0.139	4.900	0.362	0.394	3.937	4.346	10	1.75
RT315SS	0.375	*0.200	0.188	0.323	0.049	0.139	6.858	0.362	0.394	5.906	6.315	10	2.37
RT320SS	0.375	*0.200	0.188	0.323	0.049	0.139	8.827	0.362	0.394	7.874	8.283	10	2.99
RT404SS	0.500	0.313	0.313	0.437	0.059	0.154	5.339	0.480	1.969	3.984	4.551	40	2.71
RT408SS	0.500	0.313	0.313	0.437	0.059	0.154	9.276	0.480	1.969	7.921	8.488	40	4.54
RT412SS	0.500	0.313	0.313	0.437	0.059	0.154	13.213	0.480	1.969	11.858	12.425	40	6.37
RT416SS	0.500	0.313	0.313	0.437	0.059	0.154	17.150	0.480	1.969	15.795	16.362	40	8.21
RT504SS	0.625	0.400	0.375	0.547	0.079	0.200	5.622	0.598	1.969	3.984	4.685	60	3.90
RT508SS	0.625	0.400	0.375	0.547	0.079	0.200	9.559	0.598	1.969	7.921	8.622	60	6.37
RT512SS	0.625	0.400	0.375	0.547	0.079	0.200	13.496	0.598	1.969	11.858	12.559	60	8.85
RT516SS	0.625	0.400	0.375	0.547	0.079	0.200	17.433	0.598	1.969	15.796	16.496	60	11.35
RT516SS	0.625	0.400	0.375	0.547	0.079	0.200	21.370	0.598	1.969	19.732	20.433	60	13.80
RT520SS	0.625	0.400	0.375	0.547	0.079	0.200	25.307	0.598	1.969	23.669	24.370	60	16.28
RT524SS	0.625	0.400	0.375	0.547	0.079	0.200	6.047	0.598	1.969	3.984	4.882	60	4.52
RT604SS	0.750	0.469	0.500	0.661	0.094	0.235	9.984	0.720	1.969	7.921	8.819	60	6.98
RT608SS	0.750	0.469	0.500	0.661	0.094	0.235	13.921	0.720	1.969	11.858	12.756	60	9.43
RT612SS	0.750	0.469	0.500	0.661	0.094	0.235	17.858	0.720	1.969	15.795	16.693	60	11.88
RT620SS	0.750	0.469	0.500	0.661	0.094	0.235	21.795	0.720	1.969	19.732	20.630	60	14.33
RT624SS	0.750	0.469	0.500	0.661	0.094	0.235	25.732	0.720	1.969	23.669	24.567	60	16.78

*The base chain for RT305SS, RT310SS, RT315SS and RT320SS is rollerless. The value shown is for the bushing diameter. This chain uses standard ANSI sprockets.

Section D

E. Plastic BelTop Chain

Engineered plastic belt-shaped chain commonly used in bottling, canning, and other general applications. BelTop Chain offers the power and reliability of a chain system with the smooth operation of a belt. The chain is used for linear conveyance, accumulation, side loading, and movement of cans, bottles, or other materials that are easily scratched. Accumulation and movement with BelTop Chain is smoother than a system with several strands of engineered plastic Top Chains. The BelTop chain consists of engineered plastic modular links with small pitch and pins. There are specially shaped snap rings installed on both ends of the pin to prevent it from falling out.

Special features include the following:

- (1) Large conveying width (up to 10 feet).
- (2) No slippage.
- (3) Easy to maintain. The chain consists of only three parts; therefore, it is easy to assemble, connect, and disconnect. If a single link breaks, only the broken parts need to be replaced.
- (4) Small sprockets may be used to ensure smooth transfer between conveyors.
- (5) Sprockets prevent tracking problems – difficult to prevent when using a conventional belt.
- (6) It is easy to maintain a clean and sanitary operation. Therefore, BelTop chain is widely used in the food industry.



MP

Features a short chain pitch of 1/2" and is ideal for the conveying small containers such as vials and other small containers used for medical supplies or food items. This chain provides smooth, stable transition during entry and exit of washers and other treatment machines. The unique multiple hinge construction provides stable conveying during line accumulation as well as conveyor transition, startup and stopping. Its materials have the ability to release static electricity buildup that is commonly found in dry conveying conditions.

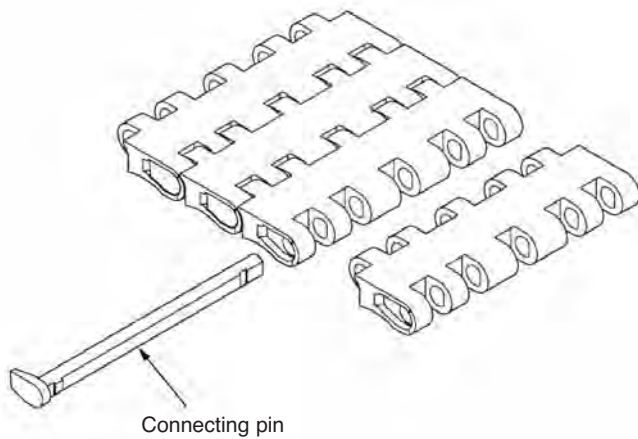
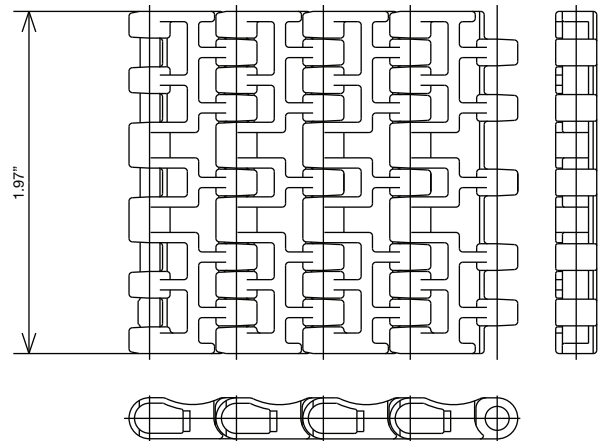
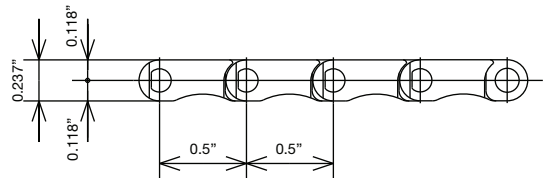

Chain Number	All types (ex UMW/Y) Maximum Allowable Load (lbs.)	UMW type Maximum Allowable Load (lbs.)	Y type Maximum Allowable Load (lbs.)	Approx. Weight (lbs./ft.)
MP4-500	110	75	55	0.17

Consult Tsubaki Technical Support for sprocket information.

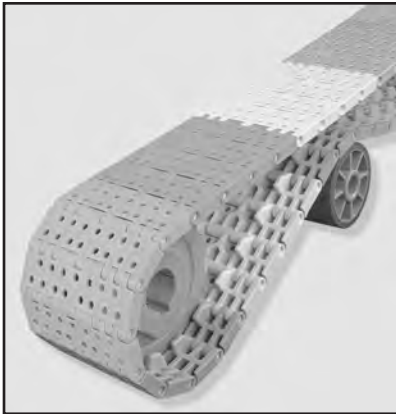

BTO

Uses an alternating combination of modular engineering plastic links to connect its wide surfaces as well as chain-sprocket meshing for a strong, reliable drive. Smaller chain pitch sizes and smaller sprockets provide a much smoother transition between conveyors. The beveling at both ends of the plates and the 3 1/4" plate width make this chain ideal for conveying items such as bottles that are easily caught in the space between the plates of multi line conveyors. Open holes in the links (17% of the surface is open) allow water to pass through. The chain is constructed only of modular links, pins and snap attachments that simplify assembly and disassembly. Even if a link does break, it can be replaced quickly – minimizing maintenance and downtime.

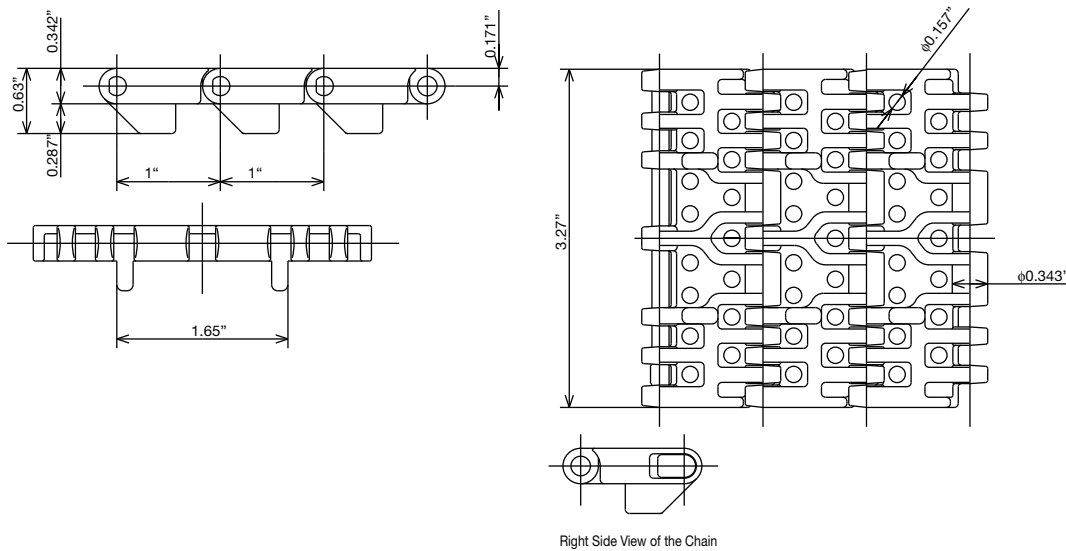

Chain Number	All types (ex UMW) Maximum Allowable Load (lbs.)	UMW Type Maximum Allowable Load (lbs.)	Approx. Weight (lbs./ft.)
BTO8-830	240	185	0.47

Consult Tsubaki Technical Support for sprocket information.

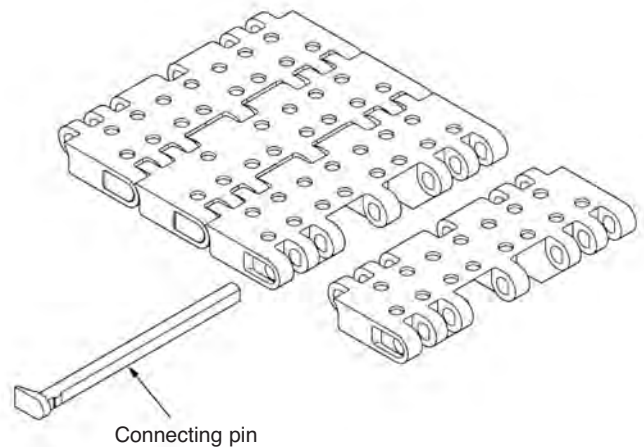

Section D

Poly-Steel (PC)

These chains are lube-free chains and are often used in food or medicine production. PC Chains can be used in power-transmission applications, and, with the addition of attachments on the outer plates, as conveyors.

The chain construction consists of outer links (outer plates and pins) made of type 304 stainless steel (clips are type 301 stainless steel), and inner links made of engineered plastic. There are no rollers.

Features include the following:

- (1) Inner links are made of a self-lubricating material; and so the chains do not require lubrication. The wear resistance of these chains is higher than that of Stainless Steel Roller Chains without lubrication.
- (2) Because the inner link is made of plastic, the noise caused by engagement with the sprocket is lower (about 5 dB lower than Standard Roller Chain).
- (3) PC Chain is very light - about half that of Standard RS Roller Chains.



Selection and handling of PC chain requires special attention. The ratio between tensile strength and maximum allowable tension for Poly-Steel chain is low. Almost all the shock load is absorbed by the engineered plastic inner link. When selecting Poly-Steel chain, the maximum allowable tension – including inertia shock must be considered to get satisfactory performance and to avoid chain breakage. Working temperature range: $-10^{\circ}\text{F} \sim +176^{\circ}\text{F}$

Corrosion Resistant Poly-Steel (PC-SY)

Similar properties and selection to Poly-Steel (PC) chain. PC-SY chain uses titanium for the pins and outer link plates and engineered plastic for the inner link. It has better corrosion resistance than PC chain. The maximum allowable load is 60% that of Poly-Steel Chain (PC). Working temperature range: $-4^{\circ}\text{F} \sim +176^{\circ}\text{F}$.

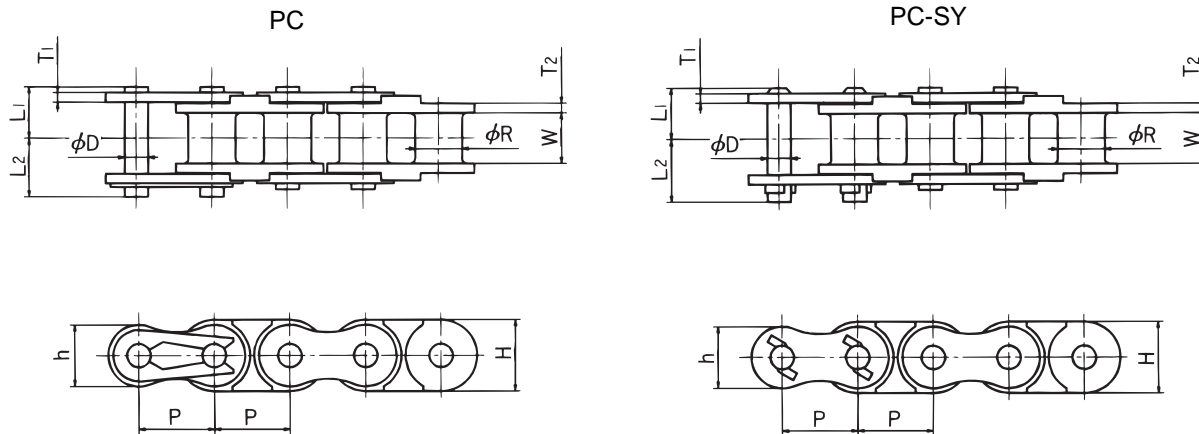

Chain Number	Pitch P	Bushing Dia. R	Width Between Inner Link Plates W	Link Plate				Pin			Maximum Allowable Load (lbs.)	Approx. Weight (lbs/ft.)	Number of links per 10 feet
				Thickness T ₁	Thickness T ₂	Height H	Height h	Dia. D	Length L ₁	Length L ₂			
Standard Specification													
RF25PC	0.250	0.130	0.125	0.030	0.051	0.236	0.199	0.091	0.177	0.217	18	0.06	160
RF35PC	0.375	0.200	0.188	0.050	0.087	0.354	0.307	0.141	0.270	0.309	40	0.15	320
RF40PC	0.500	0.312	0.312	0.060	0.060	0.472	0.409	0.156	0.325	0.392	100	0.26	240
RF50PC	0.625	0.400	0.375	0.080	0.080	0.591	0.512	0.200	0.406	0.472	155	0.39	192
RF60PC	0.750	0.469	0.500	0.094	0.094	0.713	0.614	0.234	0.506	0.581	200	0.55	160
Corrosion Resistant Specification													
RF40PC-SY	0.500	0.312	0.312	0.060	0.060	0.472	0.409	0.156	0.325	0.392	55	0.26	240
RF50PC-SY	0.625	0.400	0.375	0.080	0.080	0.591	0.512	0.200	0.406	0.472	90	0.39	192
RF60PC-SY	0.750	0.469	0.500	0.094	0.094	0.713	0.614	0.234	0.506	0.581	110	0.55	160

Plastic Chain Material Availability Matrix

Choose the right chain/material for your application.

Refer to the descriptions of all of these plastic materials at the front of the Plastic Chains section.

Colour of the plastic	White General Usage	Blue Ultra Low Friction	MW - White MWG - Green MWB - Brown Low Friction	Cream Anti- bacterial Anti-mold	Black Heat Resistant/ High Speed	Black Heat Resistant/ High Speed	Off white Super Corrosion Resistant	Off White Corrosion Resistant	White Acid Resistant	Black Electro- conductive Resistant	Light Gray Static Resistant	Off White High Friction	Light Gray Ultraviolet Resistant
Plastic material characteristics			MW/ MWG/ MWB	MWS	KV180	KV250	SY	Y	AR	E	SE	HF	UVR
Tsbusaki material codes	Standard	UMW											
RS Plastic Chain													
RS35P, 40P, 50P, 60P	•	•	•	•	•	•	•	•	•	•	•	•	•
RS2040P	•	•	•	•	•	•	•	•	•	•	•	•	•
RSP40P, 60P	•	•	•	•	•	•	•	•	•	•	•	•	•
RS60P-2	•	•	•	•	•	•	•	•	•	•	•	•	•
RS60PU	•	•	•	•	•	•	•	•	•	•	•	•	•
RS60PU-2	•	•	•	•	•	•	•	•	•	•	•	•	•
RSP60PU	•	•	•	•	•	•	•	•	•	•	•	•	•
Top Chain - linear movement													
TTP635, 762, 1016, 1270, 1524, 1651, 1905	•	•	•	•	•	•	•	•	•	•	•	•	•
TTP826	•	•	•	•	•	•	•	•	•	•	•	•	•
TTP1143	•	•	•	•	•	•	•	•	•	•	•	•	•
TTP635P, 762P, 1016P, 1270P, 1524P, 1651P, 1905P	•	•	•	•	•	•	•	•	•	•	•	•	•
TTP826P	•	•	•	•	•	•	•	•	•	•	•	•	•
TTP1143P	•	•	•	•	•	•	•	•	•	•	•	•	•
TP762-I, 826-I	•	•	•	•	•	•	•	•	•	•	•	•	•
TP826P-II, 1143P-II	•	•	•	•	•	•	•	•	•	•	•	•	•
TP762-II, 826-II, 1016-II, 1143-II, 1270-II	•	•	•	•	•	•	•	•	•	•	•	•	•
TPH830, 830P	•	•	•	•	•	•	•	•	•	•	•	•	•
MTP826T, 826SNT	•	•	•	•	•	•	•	•	•	•	•	•	•
MTP826P-SNT	•	•	•	•	•	•	•	•	•	•	•	•	•
TN, TN-NP, TN-NP-LAMBDA	•	•	•	•	•	•	•	•	•	•	•	•	•
TN-SS	•	•	•	•	•	•	•	•	•	•	•	•	•
TN-PC	•	•	•	•	•	•	•	•	•	•	•	•	•
Top Chain Curved Movement													
TTUP826	•	•	•	•	•	•	•	•	•	•	•	•	•
TTUP1143, 1905	•	•	•	•	•	•	•	•	•	•	•	•	•
TTUP826P, 1143P	•	•	•	•	•	•	•	•	•	•	•	•	•
TPU826	•	•	•	•	•	•	•	•	•	•	•	•	•
TPU826P	•	•	•	•	•	•	•	•	•	•	•	•	•
MTPU826T	•	•	•	•	•	•	•	•	•	•	•	•	•
TPSR826T	•	•	•	•	•	•	•	•	•	•	•	•	•
TNU, TNU-NP	•	•	•	•	•	•	•	•	•	•	•	•	•
TNU-AS	•	•	•	•	•	•	•	•	•	•	•	•	•
Snap Cover Chain													
Snap Cover Chain (SC)	•	•	•	•	•	•	•	•	•	•	•	•	•
SC-Stainless Steel	•	•	•	•	•	•	•	•	•	•	•	•	•
SC-Lambda	•	•	•	•	•	•	•	•	•	•	•	•	•
RT and ST Roller Table Chain													
RT and ST-Roller Table	•	•	•	•	•	•	•	•	•	•	•	•	•
BelTop Chain													
MP4-500	•	•	•	•	•	•	•	•	•	•	•	•	•
BT08-830	•	•	•	•	•	•	•	•	•	•	•	•	•
Poly-Steel Chain													
RF25PC, 35PC	•	•	•	•	•	•	•	•	•	•	•	•	•
RF40PC, 50PC, 60PC	•	•	•	•	•	•	•	•	•	•	•	•	•

• Indicates that the chain is available in that material.

Section D

All dimensions in inches unless otherwise stated.

Chain Type	Materials		Specifications				Feature	Applications	
	Chain/Pin	Top Plate	Max. Allowable Load lbs.	Suggested Max. Speed (ft./min.)		Ambient Temperature °F			
				Lubricated	Dry				
Linear Movement	TP	304 stainless steel	Plastic resin	264	330	160	-4~170	Self-lubrication, quiet-operation, Anti-corrosive, suitable for transportation of small size goods due to small clearance between top plates.	Conveying steel, cans, finished parts, paper-packages, etc.
	TTP			187					
	TN	Carbon steel	Plastic resin	1,628	390	200	15~170	Damage-free, quiet operation. Smooth transportation, easy removal of top plate. Easy repair.	
	TN-NP	Nickel-plated Carbon steel							
	TN-SS	304 Stainless steel		231	230	150	-4~170		
	RS-P	304 Stainless steel	Plastic resin	40P, 2040P: 99 60P : 198	200	200	-4~170	Quiet and trouble-free operation with anti-corrosive protection.	Conveying electronic parts and small items.
Curved Movement	TO	Carbon steel	18 Chrome stainless steel	660	200	200	15~350	Any horizontal curved operation is possible. Min. radius: 4.00 inches. Complex curved operation is available.	Suitable for horizontal curved operations.
	TU			220					

Top Plate Chain Selection

Follow the procedure below to select top chain and liner that are most economical and suitable for the application.

- Step 1: Establish general conveyor conditions
- Step 2: Select top plate material
- Step 3: Select liner material
- Step 4: Determine factors and coefficients
- Step 5: Select top plate width
- Step 6: Calculate chain tension
- Step 7: Determine chain size

Step 1

Establish general conveyor conditions

- A) Materials conveyed
 - (1) Container material
 - (2) Weight
 - (3) Dimensions
- B) Conveyor arrangement
 - (1) Straight or curved movement
 - (2) Conveyor length
 - (3) Layout
 - (4) Space limitations
- C) Other conditions
 - (1) Conveyor capacity
 - (2) Interval
 - (3) Conveyor speed
 - (4) Lubrication requirements
 - (5) Material conveyance regularity
- D) Environment
 - (1) Temperature
 - (2) The presence of corrosive chemical substances (See Table I)
 - (3) Existence of wear causing agents, such as glass, paint, metal, powder, or sand.

Table I must be referred to when selecting chain and liner materials to be used with top chain. The table shows the results of lab tests at 68°F. It is to be used for reference only and does not state or imply any warranty conditions whatsoever. Humidity and other conditions must also be considered.

Table I: Corrosion Resistance to Various Fluids

Fluid	Steel	Stainless Steel				Ultra-high Polymer Polyethylene
		Plastic	304	18 Chrome	13 Chrome	
Acetone	×	○	○	○	○	○
Oils (vegetable and mineral)	○	○	○	○	○	○
Alcohol	○	○	○	○	○	○
Aqueous ammonia	△	○	○	○	○	○
Sodium chloride	×	○	△	△	×	○
Hydrochloric acid (2%)	×	×	×	×	×	×
Sea water	×	△	△	×	×	○
Hydrogen peroxide	×	×	○	○	△	○
Caustic soda (25%)	×	×	○	○	○	○
Gasoline	○	○	○	○	○	△
Formic acid	×	×	×	×	×	○
Formic acid aldehyde	○	○	○	○	○	○
Milk	○	○	○	○	○	○
Lactic acid	×	○	○	×	×	○
Citric acid	×	△	○	△	△	○
Acetic acid (5%)	×	×	○	○	×	○
Carbon tetrachloride	△	○	△	△	△	△
Nitric acid (5%)	×	×	○	○	△	△
Rice vinegar (5%)	×	○	△	△	×	○
Hypochlorite soda	×	×	×	×	×	○
Soapy water	△	○	○	○	○	○
Paraffin	○	○	○	○	○	○
Beer	○	○	○	○	○	○
Fruit juice	×	○	○	△	△	○
Wine	○	○	○	○	○	○
Whiskey	○	○	○	○	○	○
Benzene	○	○	○	○	○	△
Water	×	○	○	○	○	○
Vegetable juice	△	○	○	○	○	○
Iodine	×	×	×	×	×	×
Sulfuric acid	×	×	×	×	×	×
Phosphoric acid	×	×	△	×	×	○
Soft drinks	○	○	○	○	○	○

○: Totally resistant △: Partially resistant ×: Not suggested

Step 2 Select top plate material.

Top plate material must be selected according to the type of goods to be moved.

Table II: Plate Material Selection Guide

Material Conveyed	Top Plate Material	Dry		Lubricated	
		Abrasive Atmosphere			
		No	Yes	No	Yes
Tin cans, aluminum cans, and metal containers (beer cans, soft drink cans and other cans having metal tops and bottoms, and fiber sides).	Plastic	○	×	○	▼
Industrial parts (machine parts, dies, castings, forgings, metals, bearings, bolts, nuts, etc.)	Stainless Steel	▼	○	▲	○
Plastics and plastic covered containers and paper containers (for milk products such as milk, cheese, ice cream and confectionery, includes containers with paper boards and paper bottoms such as those for soap and cereal).	Plastic	▼	×	▲	▼
	Stainless Steel	○	○	○	○
Glass jars, glass products and ceramics (for spirits, foods, pharmaceuticals and cosmetics).	Plastic	▼	×	▲	×
	Stainless Steel	○	○	○	○

○ Suggested ▲ Good ▼ Limited use × Not suggested

Step 3 Select liner material

The appropriate liner material must be selected from the top plate materials listed under step 2.

Table III: Liner Material Selection Guide

Top Plate Material (chain type)	Liner Material	Dry		Lubricated	
		Abrasive Atmosphere			
		No	Yes	No	Yes
Plastic	Stainless Steel	▼	▼	○	○
	Steel	○	○	▲	▲
	Super-high-polymer polyethylene	▼	×	▲	▼

○ Suggested ▲ Good ▼ Limited use × Not suggested

Section D

Step 4 Determine factors and coefficients (f_2 , f_3 , k_2 , k_3)

Table IV: Coefficient of Friction (f_2) between Top Plate and Liner

Top Plate Material	Lubrication	Coefficient of Dynamic Friction of Liner Material		
		Stainless Steel	Steel	Ultra High Polymer Polyethylene
Plastic	Dry	0.25	0.25	0.25
	Lubrication by soapy water	0.15	0.15	0.15

Table V: Coefficient of Friction (f_3) between Material Conveyed and Top Plate

Material Conveyed	Lubrication	Coefficient of Dynamic Friction of Top Plate Material
		Plastic
Plastic and paper containers and film packages.	Dry	0.25
	Lubrication by soapy water	0.10
Cans (with metal tops and bottoms)	Dry	0.25
	Lubrication by soapy water	0.15
Bottles and ceramics	Dry	0.40
	Lubrication by soapy water	0.20
Industrial parts (metal)	Dry	0.25
	Oil Lubrication	0.15

Table VI: Angle Factor (k_2) and Length Factor (k_3)

Turning Angle	Length Factor (k_3)	Angle Factor (k_2)	
		TPU and TNU Chains	
		Dry	Lubricated
30°	0.5	1.15	1.10
60°	1.0	1.30	1.15
90°	1.6	1.50	1.25
120°	2.1	1.70	1.35
150°	2.6	1.90	1.50
180°	3.1	2.20	1.60

k_2 and k_3 factors are to be used for curved movement except for TO and TU type.

$$k_3 = \pi \times \text{Turning Angle} / 180^\circ$$

Step 5 Select top plate width

Generally, the top plate must be wider than the material conveyed. When materials are very wide and none of the top plate widths are satisfactory, top plates of the same width may be used in multi-strand arrangement. Top plates of different widths can be used together, but this is not desirable since the tension on the chains will be uneven.

Step 6 Calculate chain tension (T)

1) Linear movement

(TS, TTP chains)

$$T = (M + 2.1 w) Lf_2 + ML'f_3 \dots \dots \dots \text{Formula 1}$$

2) Curved movement

(TRU, TKU, and TTU chains)

The chain tension for curved movement is calculated similarly to that for linear movement. The tension at corners, however, is compensated for by angle factor (k_2) and length factor (k_3). Calculations are shown below for the illustrated examples.

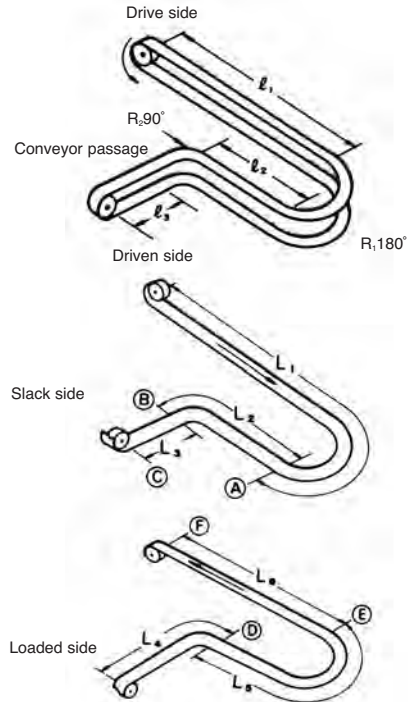

The tension on the chain at each part ABC . . . F must be calculated. The tension at F is the greatest acting on the chain.

$$T = T_{\text{F}} \dots \dots \dots \text{Formula 2}$$

Slack side:

Chain tension at A : T_{A}

$$T_{\text{A}} = L_1 w f_2 k_2, \quad L_1 = \ell_1 + R_1 k_3 \quad (k_2 \text{ and } k_3 \text{ at } 180^\circ)$$

Chain tension at B : T_{B}

$$T_{\text{B}} = \{T_{\text{A}} + L_2 w f_2\} k_2, \quad L_2 = \ell_2 + R_2 k_3 \quad (k_2 \text{ and } k_3 \text{ at } 90^\circ)$$

Chain tension at C : T_{C}

$$T_{\text{C}} = T_{\text{B}} + L_3 w f_2, \quad L_3 = \ell_3$$

Loaded side :

Chain tension at D : T_{D}

$$T_{\text{D}} = \{T_{\text{C}} + (M + w) L_4 f_2 + ML'_4 f_3\} k_2, \quad L_4 = \ell_4 + R_4 k_3 \quad (k_2 \text{ and } k_3 \text{ at } 90^\circ)$$

Chain tension at E : T_{E}

$$T_{\text{E}} = \{T_{\text{D}} + (M + w) L_5 f_2 + ML'_5 f_3\} k_2, \quad L_5 = \ell_5 + R_5 k_3 \quad (k_2 \text{ and } k_3 \text{ at } 180^\circ)$$

Chain tension at F : T_{F}

$$T_{\text{F}} = T_{\text{E}} + (M + w) L_6 f_2 + ML'_6 f_3$$

3) TO and TU chains

Calculations for chain selection vary according to their usage and arrangement. A sample calculation is given below for the arrangement shown on the right.

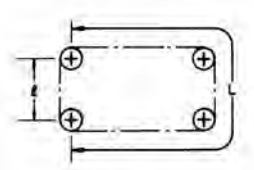

$$T = (M + w) Lf_2 + w\ell f_2 + ML'f_3 \dots \dots \dots \text{Formula 3}$$

4) Calculation of power required

$$HP = \frac{TS}{33,000 \times \eta} \dots \dots \dots \text{Formula 4}$$

Step 7 Determine chain size

Multiply the maximum chain tension (T) by the speed coefficient (k_1) taken from Table VII and verify that the following equation is satisfied.

$$T \times k_1 \leq \text{Chain maximum allowable load}$$

..... Formula 5

When the maximum allowable load is insufficient, it can be corrected by using top plates with narrower width and increasing the number of chain strands, or by splitting into many short conveyors.

Table VII: Speed Coefficient (k_1)

Chain Speed (ft./min.)	Speed Factor (k_1)
0 ~ 50	1.0
50 ~ 100	1.2
100 ~ 160	1.4
160 ~ 230	1.6
230 ~ 300	2.2
300 ~ 360	2.8
360 ~ 400	3.2

- T : Chain tension (lbs.)
- M : Weight of material conveyed
per ft. (lbs./ft.)
- w : Chain weight (lbs./ft.)
- L : Center distance between sprockets (ft.)
- ℓ : Distance not loaded (ft.)
- L' : Distance of the material sliding on the
chain for storage
(L'=0 when items and chain are not
slipping)
- f_2 : Coefficient of friction between the top
plate and liner (See Table IV)
- f_3 : Coefficient of friction between goods
moved and top plate (See Table V)
- k_1 : Speed coefficient (See Table VII)
- k_2 : Angle factor (See Table VI)
- k_3 : Length factor (See Table VI)
- R : Radius at corner (ft.)
- S : Chain speed (ft./min.)
- η : Mechanical transmission efficiency
for drive unit
- HP : Power required

Section D

1. Chain size

Chart 1: Allowable load (lbs per link)

	RF06B-SC	RS40-SC	RS50-SC	RS60-SC	RS80-SC	RS100-SC
Allowable Load	6.6	11	15.4	22	33	55

(1) Confirm that the load per link is within the allowable load, for the chain size, shown in chart 1.

(2) Calculation of Load applied to the chain

F	= Maximum load applied to chain	(lbs)
m1	= Weight of conveyed materials	(lbs/ft)
m2	= Chain weight	(lbs/ft)
S	= Conveyor length (Distance between sprocket centers)	(ft)
S'	= Distance of conveyed materials slip and stop	(ft)
μ_1	= Coefficient of Friction between chain and guide rail (Conveying side)	(Chart 2)
μ_2	= Coefficient of Friction between chain and guide rail (Return side)	(Chart 3)
μ_3	= Coefficient of Friction between conveyed materials and chain	(Chart 4)
P	= Required power	(HP)
V	= Chain speed	(ft/min)
K	= Speed coefficient	(Chart 5)
η	= Mechanical transmission efficiency of drive unit	
G	= 9.80665m/s^2	

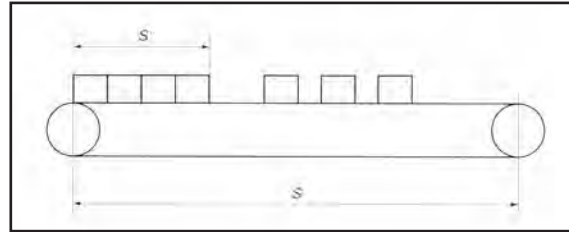

Chart 2: Coefficient of friction between chain and guide rail on conveying side (μ_1)

Non-lubricated	Lubricated
0.21	0.14

Chart 3: Sliding coefficient between chain (Cover) and guide rail on return side (μ_2)

Cover Material	Guide Rail Material	
	Stainless Steel	Ultra High polymer polyethylene
Polyacetal/Electro-conductive	0.25	0.25

Chart 4 : Coefficient of Sliding Friction between conveyed materials and chain (Cover) *When non-lubricated

Cover Material	Conveyed Products Material				
	Steel & Aluminum Cans	Paper carton	Glass bottles	Plastic container	Manufacturing parts (metal)
Polyacetal / Electro-conductive	0.3	0.3	0.2	0.3	0.3

Chart 5 : Speed coefficient (K) *When non-lubricated

Chain speed (ft./min.)	Speed coefficient K
Less than 50	1.0
50 ~ 100	1.2
100 ~ 167	1.4
167 ~ 200	1.6

Calculation formula

$$F = \{(m1 + m2) S \times \mu1 + 1.1m2 \times S \times \mu2 + m1 \times S' \times \mu3\}$$

Multiply the Maximum Chain Tension (F) by the Speed coefficient (K) (refer to Chart 5) and verify that the following equations are satisfied:

Single strand conveyor: $F \times K \leq \text{Chain's Maximum Allowable Tension}$

Double strand conveyor: $0.6F \times K \leq \text{Chain's Maximum Allowable Tension}$

2. Calculation of required Power

$$P = (F \times V) / (3000 \times \eta)$$

Chain Cutting and Connecting

1) Engineering Plastic Cover

The cover can be removed by hand, however it is more easily removed using a screwdriver. When attaching the cover, ensure that it is securely fitted to the base chain.

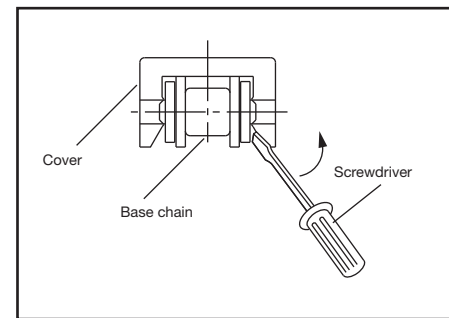

2) Disassembly of Base Chain

The connecting link pins and link plates are loose fitted. For all other links please use a punch and a hammer to remove the sets of pins. Disassembled links, other than the connecting link, cannot be used again.

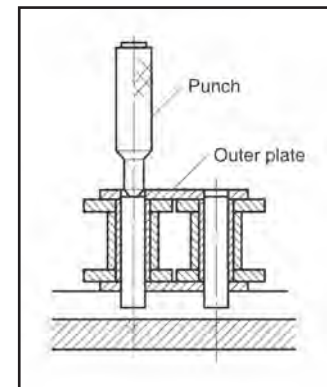

Conveyor Setup

1) Running Rail

So as to prevent chain vibration and conveyor motion pulsation, gently bend the receiving rail on the slack side to allow easy reception of the chain.

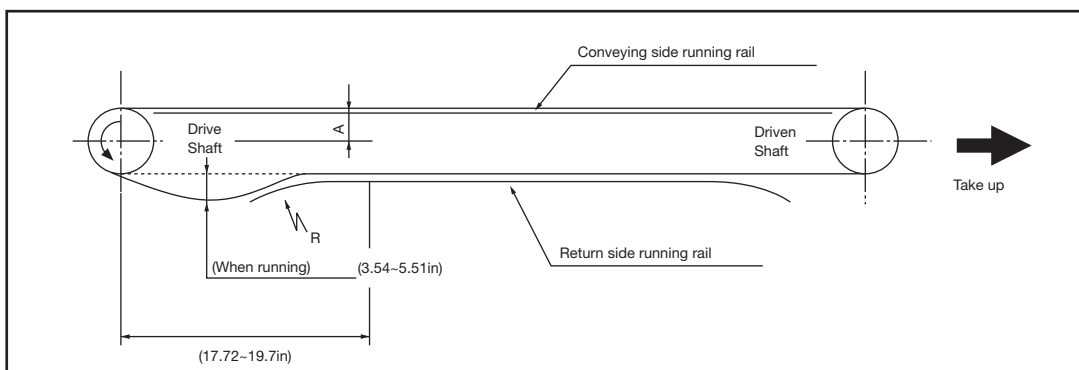

Section D

2) Chain Slack

Chain slack under the drive sprocket of 3.54" - 5.54" is required (when running).

Height of running rail

$$A = (\text{Sprocket pitch diameter} - \text{Roller diameter}) / 2$$

3) Bending of Running Rail Ends

The running rail R dimension should be larger than the chain's backbend radius R (Shown in the chart below).

All dimensions in inches unless otherwise stated.

	RF06B-SC	RS40-SC	RS50-SC	RS60-SC	RS80-SC	RS100-SC
Minimum backbend radius R	11	14.2	18.9	22	29.1	34.6

4) Chain Guide

- a) Conveying side... Ensure that only the roller runs on the guide. If the cover runs on the guide it will wear quickly.
- b) Return side... Run the whole surface of the cover on the guide.

Conveying Side

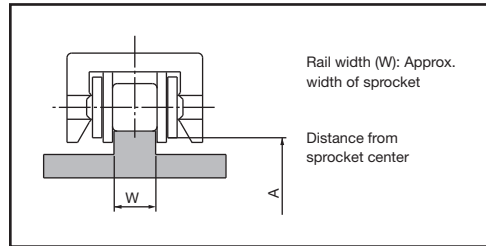

Return Side

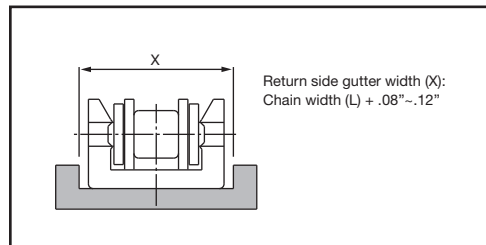

Determine The Roller Table Size With The Follow Capability Graphs:

ST Roller Table Conveyor Capability Graph

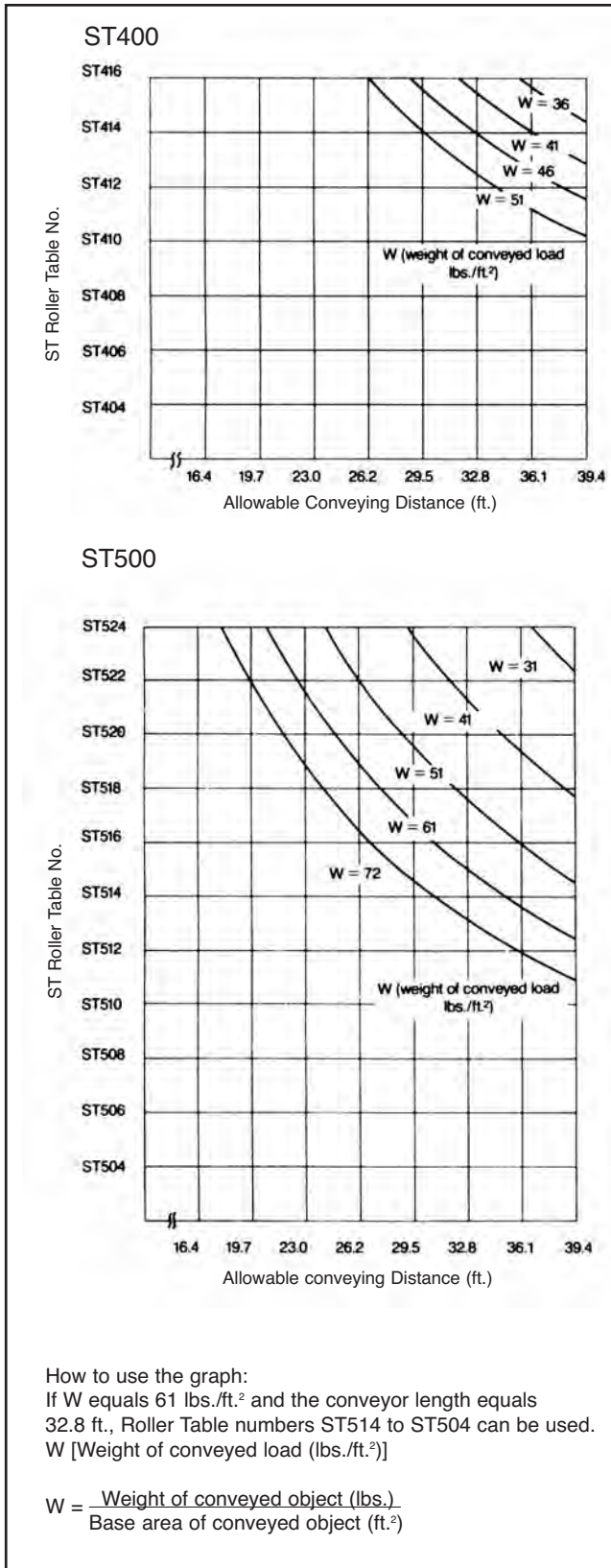

Guide for ST Roller Table

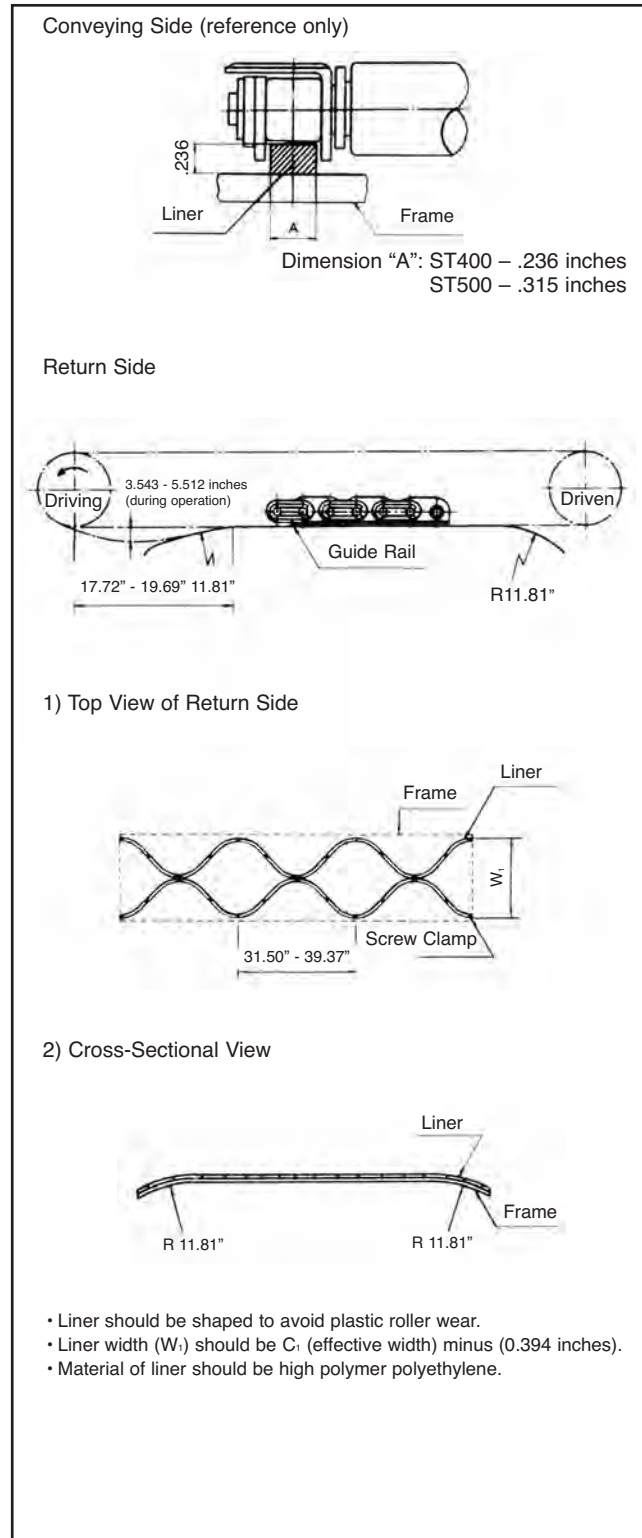

Section D

RT Roller Table Conveyor Capability Graph

RT400

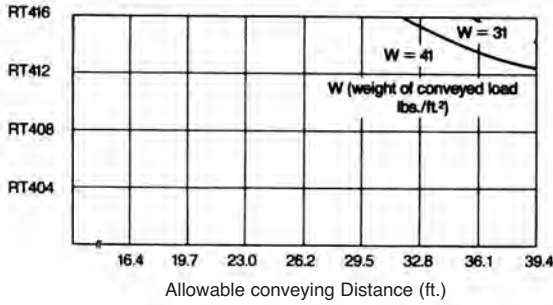

RT500

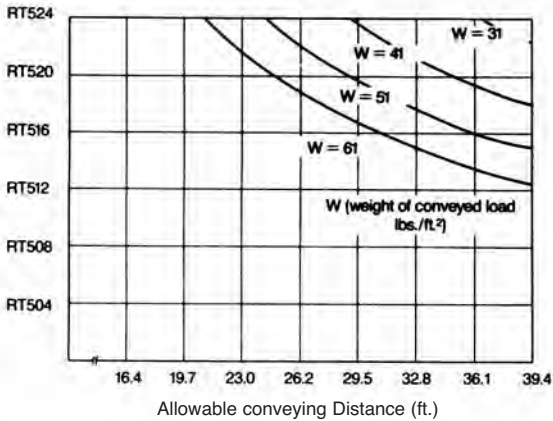

RT600

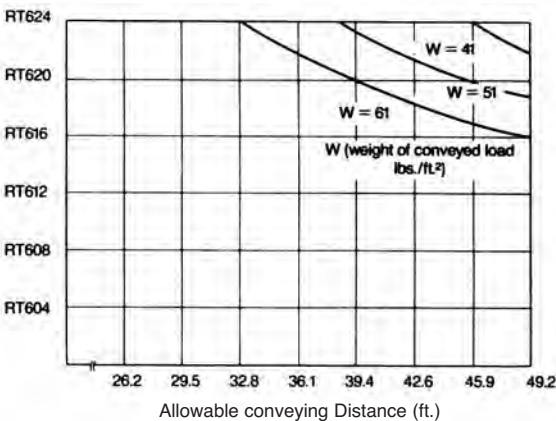

Use these graphs in the same way as for ST Roller Table.

Guide for RT Roller Table

Conveying Side

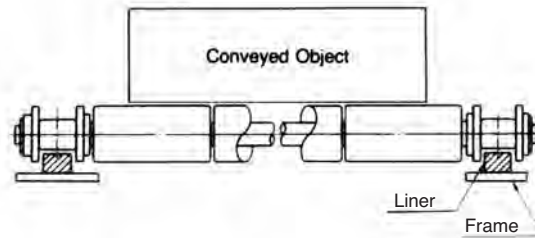

Return Side

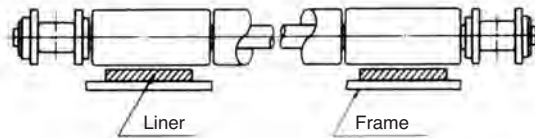

Note: Material of liner should be high polymer polyethylene.

RT Roller Table speed should not exceed 160 ft./min.

How to calculate the carrying capacity (for round containers)

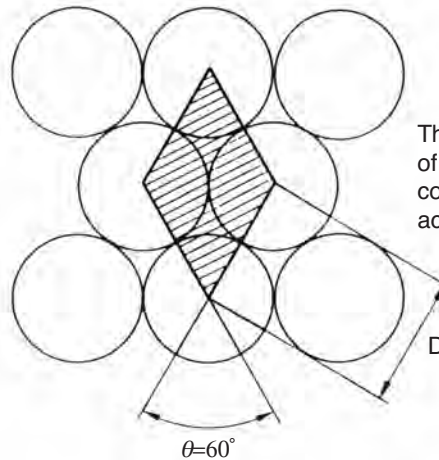

This is a sketch of the round containers accumulating.

$$W = \frac{\omega \times 1.44 \times 10^2}{D^2 \sin 60^\circ} \text{ (lbs./ft.}^2\text{)}$$

- W: Carrying capacity (lbs./ft.²)
- ω: Weight of material (lbs./p)
- D: Diameter of conveyed material (inch)

Selection Procedure Example

Specifications

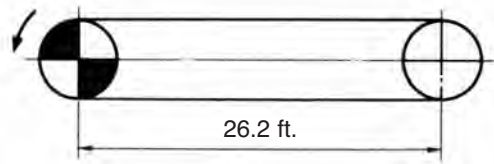

Conveyor length: 26.2 ft.
 Weight of conveyed object: 44 lbs.
 Dimensions of conveyed object: 0.98 ft. X 0.66 ft. X 0.33 ft.

Selection

For smooth conveying and to provide “side-through” transfer lines select ST-type.
 From the ST-Roller Table conveyor capability graph below:

$$W = \frac{44}{.98 \times .66} = 68 \text{ lbs./ft.}^2$$

If $W = 68 \text{ lbs./ft.}^2$ and the conveyor length is 26.2 ft., ST504 ~ ST516 Roller Table is the appropriate choice according to the following graph.

ST500

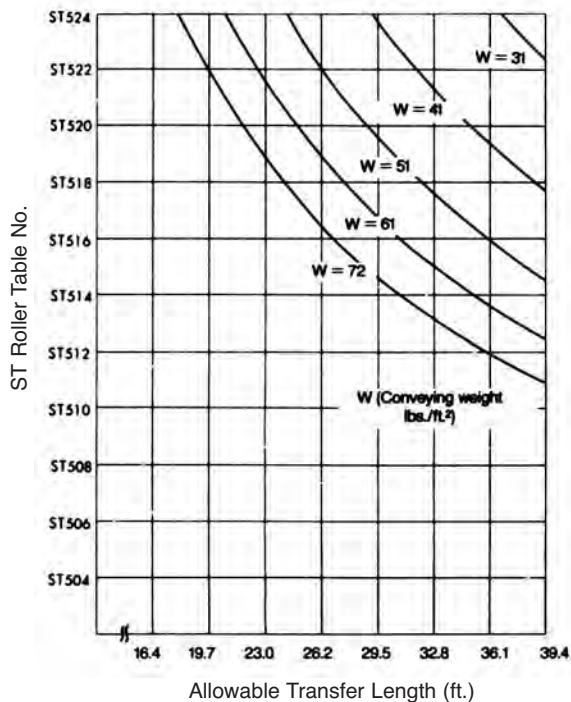

Determine the chain-width (C₁) using the dimension diagram on the preceding 2 pages.

In this example, ST510SS (NP) Roller Table chain with chain-width (C₁) (9.890”) was deemed appropriate for conveyed objects with the above dimensions.

Section D

Sample layout is shown here. Guide rail arrangement varies depending on the space. For the return side layout, see page D-39.

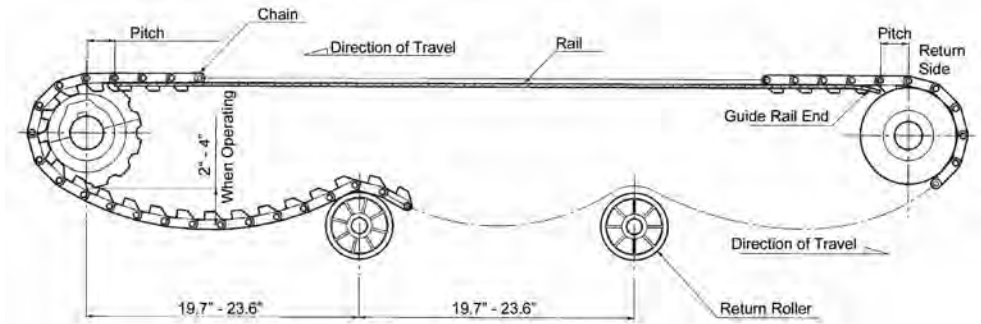

1) Amount of Chain Slack

The space between return rollers that support the return side chain should be 19.7” – 23.6” space, and amount of the chain sag between the return rollers should be 1.97” – 3.94”.

2) Engagement Angle of the Chain and Sprocket

Engagement angle of the drive sprocket and the chain should be more than 150 degrees.

3) Guide Rail End

The space between the guide rail end (both drive side and tail side) and the shaft center should be 1pitch.

Note: The guide rail end on the tail side must be radius curved or chamfered in order to avoid the edge catching the chain.

4) Heights of the Rail on the Conveying Side

Please see the illustration below.

ARRANGEMENT OF RAILS ON CONVEYING SIDE

Drive Side

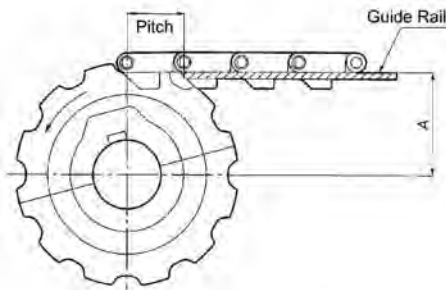

Return Side

When using an idler wheel for top plate chain

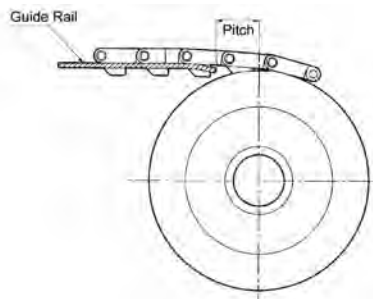

CHAIN TYPE	a
TTP, TP-II, TPH, MTP, TTUP, TPU, MTPU, TPSR, RS2040P, TT, TTU	+0.157”
TP-I	+0.197”
TN, TNU, TS, TRU	+0.433”
TKU	+0.492”
RS35P	-0.137”
RS40P	-0.216”
RS50P	-0.255”
RS60P-2, RS60PU-2	-0.295”
RS60P, RS60PU	-0.315”

$$A = \frac{\text{Sprocket Pitch Diameter}}{2} + a \text{ (inches)}$$

The diameter of the driven sprocket should be a similar diameter as the drive sprocket. Normally an idler sprocket is used for the driven side.

Guide Rail Design for Top Chain:

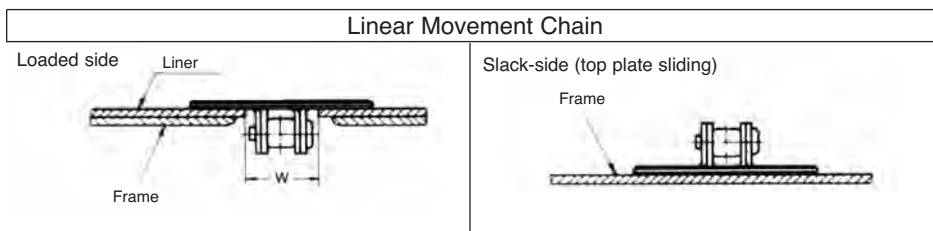

Note: TS-P type chains are shown in this illustration. Other chain types can also be used.

Guide Rail Inside Width (inches)

Chain Type	W	Chain Type	W
TS-P	1.300	TP	1.772
TTP	1.772	-	-

Curved Movement Chain

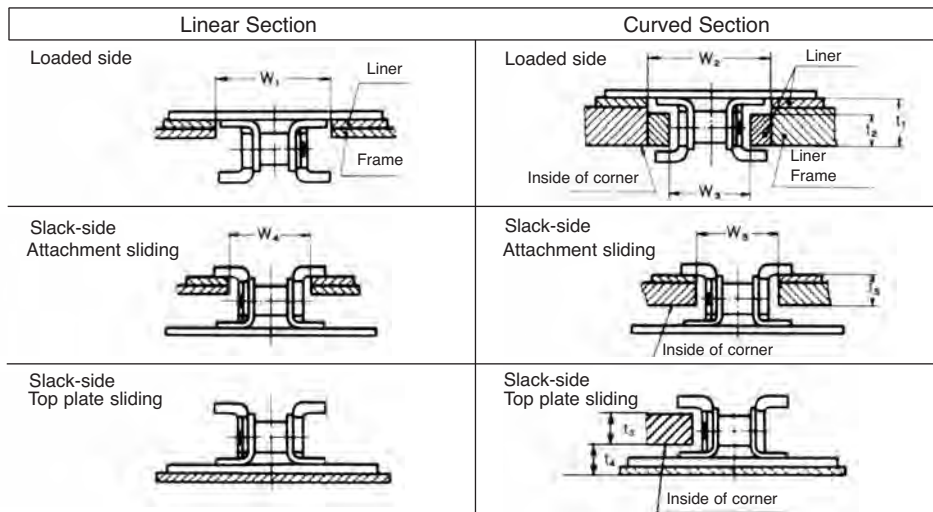

Note: TRU Steel Top Plate Chains are shown in the illustration. Other chain types can also be used.

Guide Rail Inside Width (inches)

Chain Type	W ₁	W ₂	W ₃	t ₁	t ₂	W ₄	W ₅	t ₃
TPU	1.772	1.772	1.772	.472	.472	1.890	1.890	.472
TNU	1.496	1.496	1.496	.709	.709	-	-	-

Guide Rail Design for Top Chain (slack side)

Top plate sliding (applicable for all top chains)

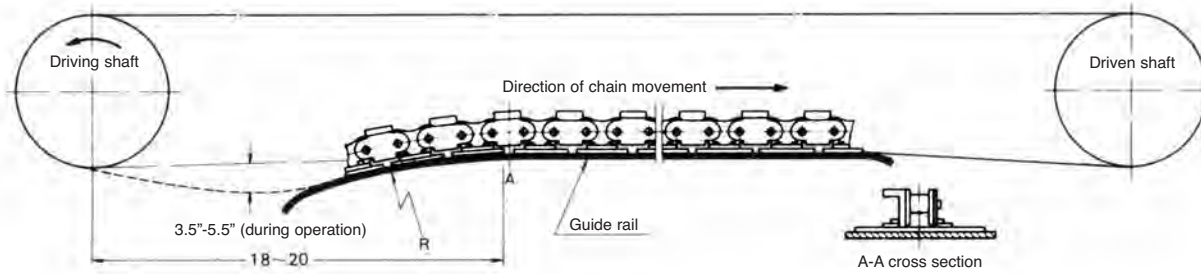

Attachment sliding (TRU type)

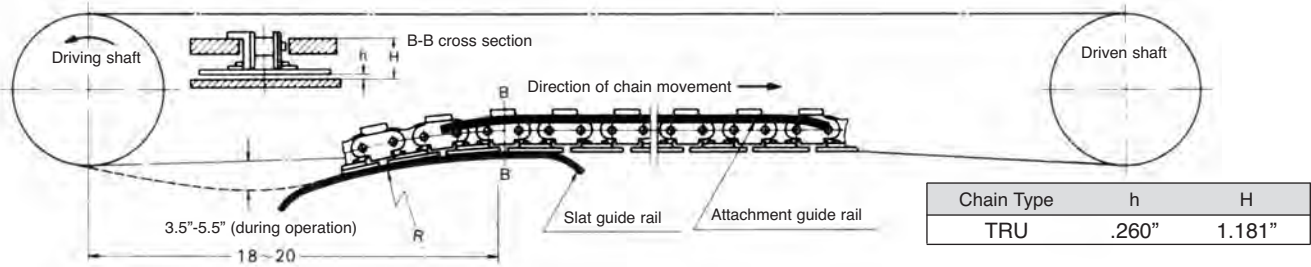

- (1) Slack of 3.5 - 5.5 inches (during operation) is needed under the drive sprocket.
- (2) Engagement angle must be more than 150° between the drive sprocket and the chain.
- (3) The radius R (inches) of the guide rail must be larger than the radius of chain back-bend given in the table below.
Radius of Chain Back-bend
- (4) Guide rails must have sloped ends to prevent interference with the chain.

Guide Rail for Sideway Transfer:

Locations of the chain and the guide rail are very important for a smooth transition between conveyors. Two parallel chains must be positioned at the same height, or the output chain must be positioned slightly higher than the receiving chain. The guide rail must be shaped such that transition of goods can be accomplished smoothly.

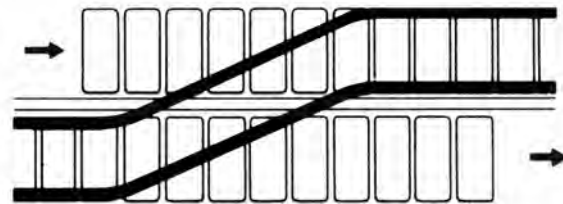

Connection of additional conveyors

If a conveyor is too long, the chain tension will increase and chain strength will not be sufficient. In such cases, additional conveyors should be used.

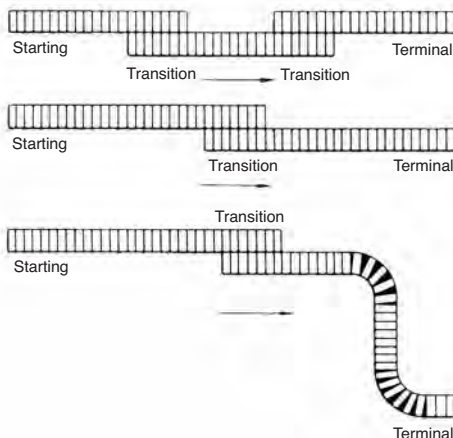

Guide Rail Setup (Linear Section):

1) Single strand chain

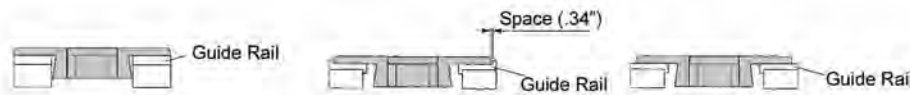

2) When 2 chains are traveling in same direction at same speed

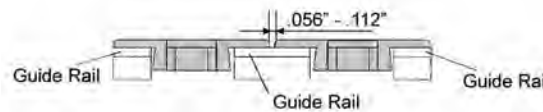

3) When 2 chains are traveling in reverse directions at different speeds

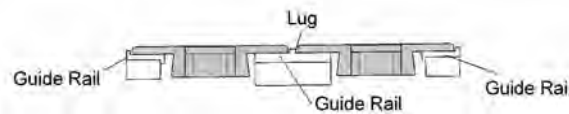

4) Chain with hold-down tab

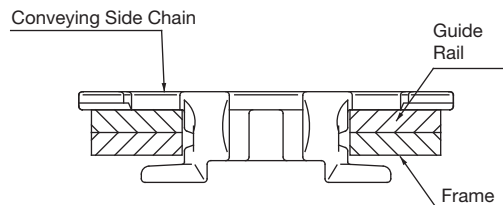

5) Arrangement of a long rail

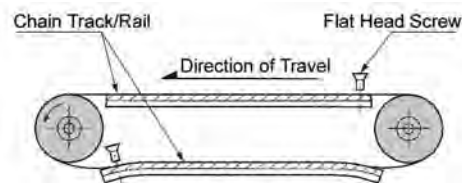

Do not fix both ends of the rails. Fix only one rail end in order to prevent the rail from breaking due to heat expansion.

Section D

RETURN SIDE LAYOUT

Layout of the return side varies depending upon the type of chain, conveying objects, flow system, and route. Typical layouts are shown below.

	<p>Roller Returns This is the most common and recommended layout. Angle of chain lap on the sprocket must be at least 150°. Make sure the return rollers rotate freely. If it does not rotate smoothly, sliding will occur, and abrasion particles or partial abrasion of the top plate may result.</p>
	<p>A: 1.97" – 3.94" (during operation) B: 19.7" – 23.6" C: Outer diameter of sprocket/2 or less</p> <p>*Please see the next pages for details This may vary depending on chain types and conveying conditions. Use only as a basic guide.</p>
	<p>Using Guide Rail Attachment By installing an attachment to prevent top plate chains rising out of the carrying way, sliding of the top plate surface can be avoided. This is suitable for the conveying conditions that damages to the top plate surface must be avoided. Angle of chain lap on the sprocket must be at least 150°.</p> <p>A: 1.97" – 3.94" (during operation) B: 19.7" – 23.6"</p> <p>* Please see the next pages for details This may vary depending on chain types and conveying conditions. Use only as a basic guide.</p>
	<p>Supporting With Rails Supporting only part of the top plates may result in partial abrasion. Use serpentine style to install rails so that the rails support entire surface of the top plates. Angle of chain lap on the sprocket must be at least 150°.</p> <p>A: 1.97" – 3.94" (during operation) B: 19.7"-23.6"</p> <p>* Please see the next pages for details This may vary depending on chain types and conveying conditions. Use only as a basic guide.</p>
	<p>Supporting with Sliding Shoe This is suitable for relatively slow speed conveying (164 ft./min or slower). Generally used for accumulation chains or Roller Table Chains (ST, RT). Angle of chain lap on the sprocket must be at least 150°.</p> <p>A: 1.97" – 3.94" (during operation) B: 19.7" – 23.6"</p> <p>*Please see the next pages for details This may vary depending on chain types and conveying conditions. Use only as a basic guide.</p>
	<p>Using Guide Rail Only Although this is a practical layout, there is a disadvantage that the top surface of the plates can be damaged. Suitable for chains with relatively large back flex radius. Angle of chain lap on the sprocket must be at least 150°. Curve radius on both ends of the guide rail must be greater than the back flex radius of the chain.</p> <p>A: 1.97" – 3.94" (during operation) B: 19.7" – 23.6"</p> <p>This may vary depending on chain types and conveying conditions. Use only as a basic guide.</p>
	<p>No Support for the Return Side Normally we don't recommend this type of conveyor layout because the tension of the return side of the chain causes chain vibration and prevents smooth operation. If this method is unavoidable due to short conveyor span (59" or less), arrange a take-up on the return side. The angle on the sprocket must be more than 150°.</p> <p>The amount of chain sag A should be approximately 10% of the conveyor span B.</p>

RETURN SIDE LAYOUT DETAILS

Cross section of conveyor using return rollers to support return side.

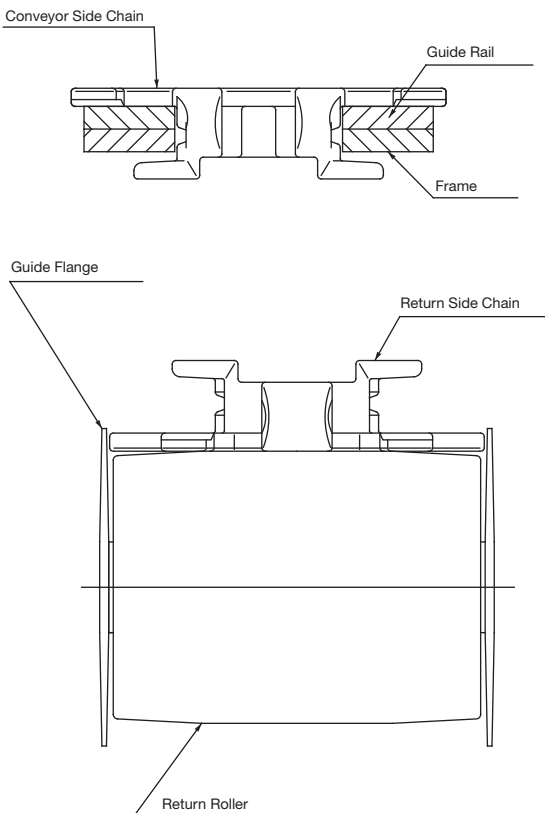

Cross section of conveyor using attachment guide rail to support the return side (avoiding damage to the top surface of slat).

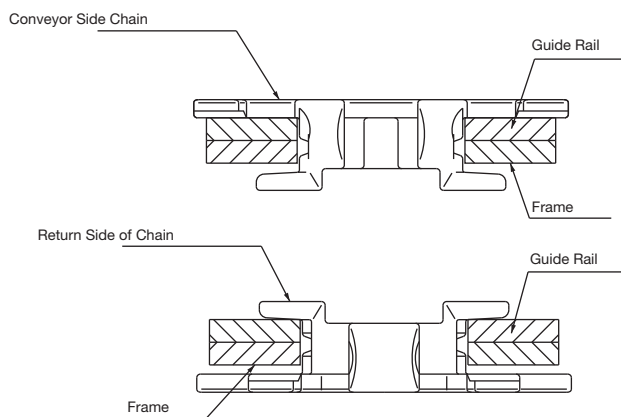

When using return rollers, check the back flex radius of a chain shown in chart 1 on the next page. The radius of the return roller must be greater than the back bend radius of the chain. If a back bend radius is up to 11.8", these preceding conditions do not apply because the chain slack can be lessened.

When using a plastic top chain, the ratio of an outer diameter and inside diameter should be [Outer: Inside = 1:4] in order to have smooth rotation of return rollers.

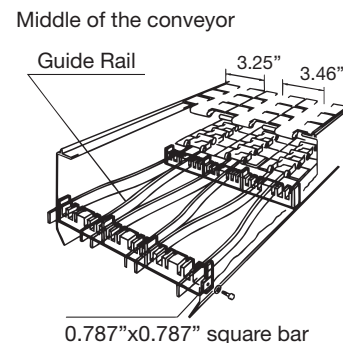
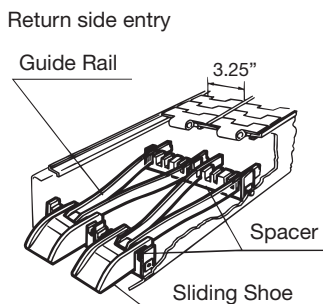
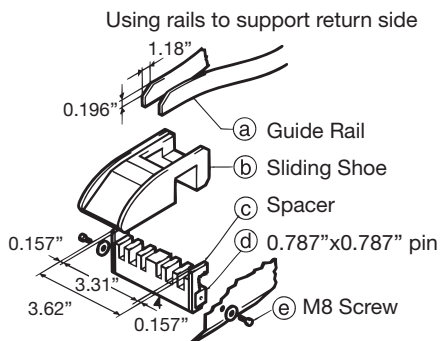

1. Attach the Sliding Shoe (b) to the Spacer (c) Cut the end of the Rail (a) as shown in the illustration (above left), and put into the groove in the Spacer (c).
 2. Place the Guide Rail (a) in a snaking style so that the top chain plate is fully supported at all points.
 3. Insert a square bar .787" x .787" (d) into the Spacer (c) to fix it to the frame.
 4. Install spacers every 19.68"-23.6" after the entry and install guide rails.
- *Suitable for a chain with a back bend radius of 2.95".

Section D

Using Sliding Shoe To Support Return Side
(164 ft./min. or slower)

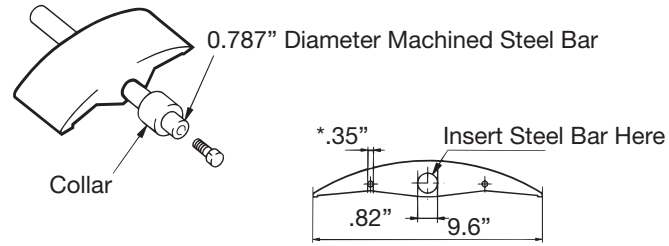
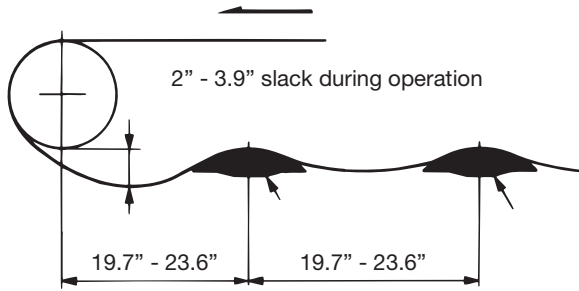

*Indicates a hole to link sliding shoes for multiple strand conveyor

* suitable for a chain with a backbend radius of less than 15-3/4\".

Insert a 0.787\" machined steel pin and fix it to the frame. Apply a collar to secure the sliding shoe in order to prevent left-right sliding.

Design For Return Side Curved Rail

Install return rollers under both ends of the curved rail in order to guide the chain. Location of the return roller should be 1.97\" - 5.9\" away from the base.

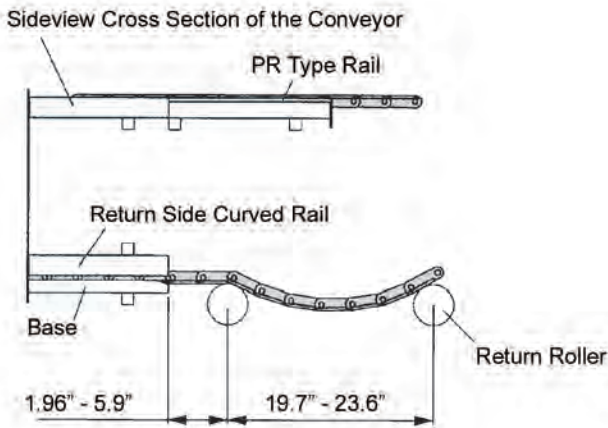

Chart 1: Back bend radius of chains (in.)

Chain Type		Back Bend Radius (in.)	
Plastic Top Plate	Linear Conveying	TTP	1.57
		TP	1.57
		TPH	1.38
		MTP826T	0.59
		MTP826SNT	0.59
		TN	3.94
	Curved Conveyors	TTUP	1.57
		TPU	1.57
		MTPU826T	0.59
		TPSR826T	0.98
TNU	3.94		

Chain Type		Back Bend Radius (in.)	
RS Plastic Chain	Linear Conveying	RS35P (KV180)	4.33 (5.91)
		RS40P	4.92
		RS50P	7.87
		RS60P	17.70
		RS60-2P	17.70
		RS2040P	35.40
	Curved Conveyors	RS60PU	9.84
		RS60PU-2	5.91

Adding Conveyors

When Conveyor span becomes longer, increase in chain tension weakens the chain strength. In this case, new conveyors should be added. There are three method of adding conveyors as shown below. It is crucial to pay attention to the conveyor heights for smooth conveying.

(1) Side Transfers by placing two chains side by side

This is the easiest and the preferred method of product transfer by installing guide rails. Heights of the two chain strands should be the same or the in-feed chain should be slightly higher. Angle of the guide rails should be adjusted to provide smooth product flow.

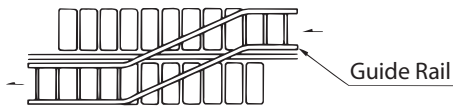

(2) Dead-plate Transfers

When two chains are placed at right angles to each other due to the flow layout, use the dead-plate transfer method. For smooth operation, the dead-plate should be slightly lower than the in-feed chain and slightly higher than the out-feed chain. Also, slightly bevel edge of the dead-plate.

The dead-plate covers the top surface of the out-feed chain, and precautions should be taken to properly install the dead-plate

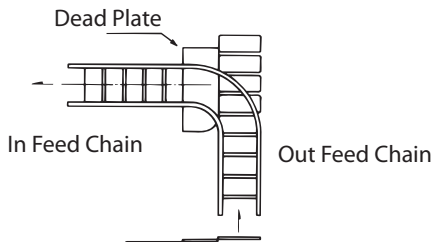

since it can float with the chordal action of the chain on the tail side.

(3) Turntable Transfers

The principle for this method is basically the same as for dead-plates. Turntables should be placed slightly lower than the in-feed

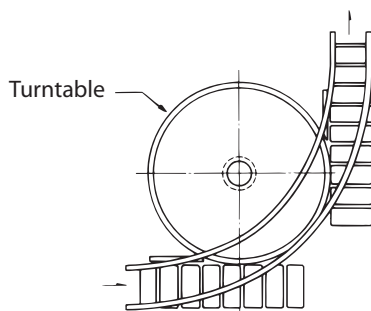

chain and slightly higher than the out-feed chain. The edge of the turntable needs to be beveled.

Important points when using the KV specification top chains

i. Using in normal temperature

1. Recommended rail materials are steel, cold rolling stainless steel, or cold rolling stainless steel with hard chrome plating and buffing.

Example: fixing stainless steel rails and leaving space between the rails.

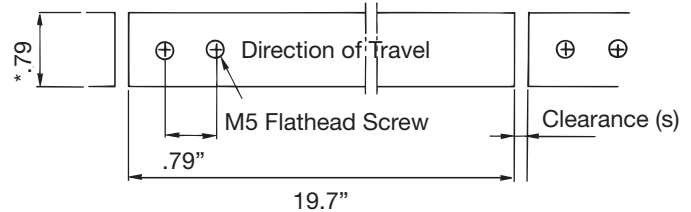

*For TTP-KV, TP-II-KV
TTUP-KV, TPU-KV
For RS40P (60P) KV Type
refer to RS pages.

Clearances for 19.7" rail
122-212°F - 0.06"
212-302°F - 0.79"
302-392°F - 0.098"
392-482°F - 0.112"

2. Black abrasion particles come out. Clean regularly.
3. Start up and stop gently

ii. Using in high temperature

1. Recommended rail material is cold rolling stainless steel.
2. Bolt only one end of the rail to allow heat expansion (otherwise it will break). Also, remember to allow heat expansion at the gap between the rails.
3. Standard steel sprockets are suitable for temperatures lower than 302°F. Please contact us for the special sprockets required for temperatures higher than 302°F.
4. Space between the chains for multiple strands is shown below.

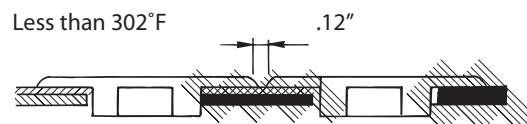
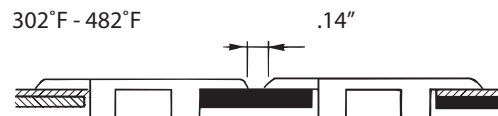

5. The take up has to be done at the same operating temperature. In order to remove the slack caused by the heat expansion of the chain loosen the take up before the chain cools down.
6. Black abrasion particles may occur. Clean regularly.
7. Start up slowly (using inverter control) and stop slowly.

Section D

DESIGN OF CORNER SECTION FOR TPSR826T

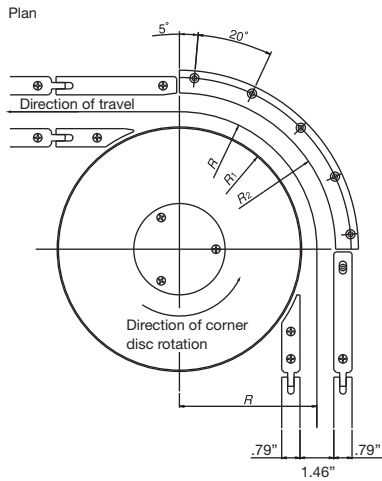
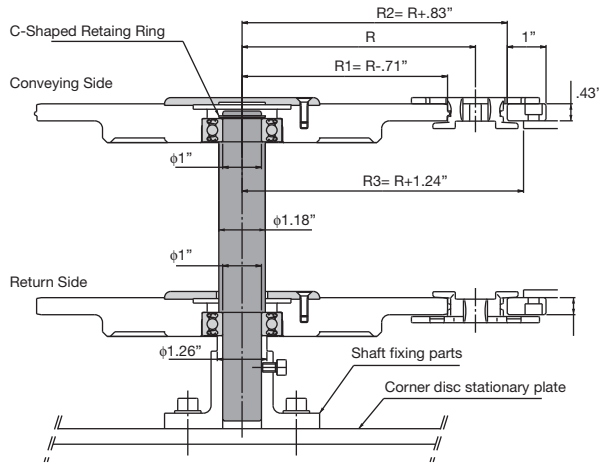

- R: horizontal curve radius of the chain (in.)
- R1: outer radius of corner disc (in.)
- R2: radius of inside of guide rail (in.)
- R3: radius of the inner curve of conveyor frame (in.)

We provide corner discs and rails in various sizes. Consult Tsubaki Technical Support for details. Install a return roller where the chain enters and leaves the corner for a guide.

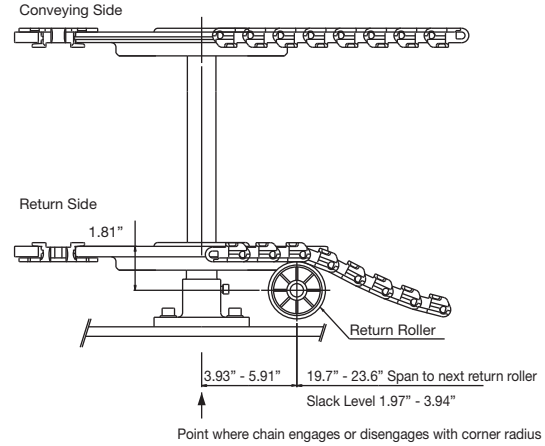

Change in Angle of Chain Travel

Make sure that the chain enters and leaves the disc in the same

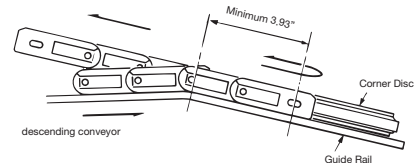
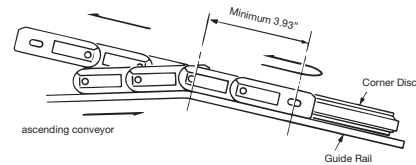

UNIVERSAL CHAIN

1. Guide Rail Layout

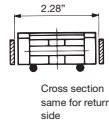
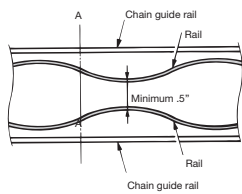

2. Guide Rail

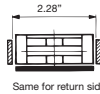

Explanation of Terms:

3. Corner Disc

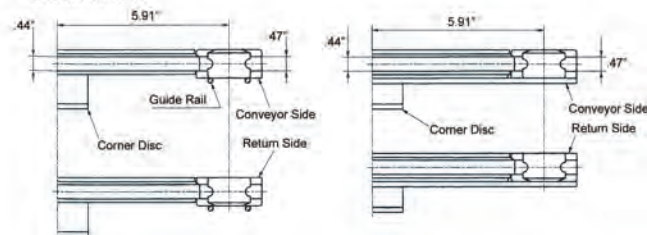

plane as the disc. This is necessary to maintain the chain on the disc.

 **WARNING****USE CARE TO PREVENT INJURY
COMPLY WITH THE FOLLOWING
TO AVOID SERIOUS PERSONAL INJURY**

1. Guards must be provided on all chain and sprocket installations in accordance with provisions of ANSI/ASME B15.1 – 1996 “Safety Standards for Mechanical Power Transmission Apparatus,” and ANSI/ASME B20.1-1996 “Safety Standards for Conveyors and Related Equipment,” or other applicable safety standards. When revisions of these standards are published, the updated edition shall apply.
2. Always lock out power switch before installing, removing, lubricating or servicing a chain system.
3. When connecting or disconnecting chain:
 - a. Eye protection is required. Wear safety glasses, protective clothing, gloves and safety shoes.
 - b. Support the chain to prevent uncontrolled movement of chain and parts.
 - c. Use of pressing equipment is recommended. Tools must be in good condition and properly used.
 - d. Determine correct direction for pin/rivet removal or insertion.

Revision 5/94

Chain Number	Pitch P	Chain Type	Page #
RS35P	0.375	Plastic Chain	D-5
RS40P	0.500	Plastic Chain	D-5
RS50P	0.625	Plastic Chain	D-5
RS60P	0.750	Plastic Chain	D-5
RSP40P	0.500	Plastic Chain	D-5
RSP60P	0.750	Plastic Chain	D-5
RS60P-2	0.750	Plastic Chain - Double Strand	D-5
RS2040P	1.000	Plastic Chain - Double Pitch	D-6
RS60PU	0.750	Plastic Chain - Curved Movement	D-7
RSP60PU	0.750	Plastic Chain - Curved Movement	D-7
RS60PU-2	0.750	Plastic Chain - Curved Movement - Double Strand	D-7
TTP635	1.500	Plastic Top Chain - TTP	D-8
TTP635P	1.500	Plastic Top Chain - TTP	D-8
TTP762	1.500	Plastic Top Chain - TTP	D-8
TTP762P	1.500	Plastic Top Chain - TTP	D-8
TTP826	1.500	Plastic Top Chain - TTP	D-8
TTP826P	1.500	Plastic Top Chain - TTP	D-8
TTP1016	1.500	Plastic Top Chain - TTP	D-8
TTP1016P	1.500	Plastic Top Chain - TTP	D-8
TTP1143	1.500	Plastic Top Chain - TTP	D-8
TTP1143P	1.500	Plastic Top Chain - TTP	D-8
TTP1270	1.500	Plastic Top Chain - TTP	D-8
TTP1270P	1.500	Plastic Top Chain - TTP	D-8
TTP1524	1.500	Plastic Top Chain - TTP	D-8
TTP1524P	1.500	Plastic Top Chain - TTP	D-8
TTP1651	1.500	Plastic Top Chain - TTP	D-8
TTP1651P	1.500	Plastic Top Chain - TTP	D-8
TTP1905	1.500	Plastic Top Chain - TTP	D-8
TTP1905P	1.500	Plastic Top Chain - TTP	D-8
TP762-I	1.500	Plastic Top Chain - TP	D-9
TP762-II	1.500	Plastic Top Chain - TP	D-9
TP826-I	1.500	Plastic Top Chain - TP	D-9
TP826-II	1.500	Plastic Top Chain - TP	D-9
TP826P-II	1.500	Plastic Top Chain - TP	D-9
TP1016-II	1.500	Plastic Top Chain - TP	D-9
TP1143-II	1.500	Plastic Top Chain - TP	D-9
TP1143P-II	1.500	Plastic Top Chain - TP	D-9
TP1270-II	1.500	Plastic Top Chain - TP	D-9
TPH830	1.500	Plastic Top Chain - TPH	D-10
TPH830P	1.500	Plastic Top Chain - TPH	D-10
MTP826T	1.500	Plastic Top Chain - MTP	D-11
MTP826SNT	1.500	Plastic Top Chain - MTP	D-11
MTP826P-SNT	1.500	Plastic Top Chain - MTP	D-11
TN826	0.750	Plastic Top Chain - TN	D-12
TN1016	0.750	Plastic Top Chain - TN	D-12
TN1143	0.750	Plastic Top Chain - TN	D-12
TN1270	0.750	Plastic Top Chain - TN	D-12
TN1905	0.750	Plastic Top Chain - TN	D-12
TN826NP	0.750	Plastic Top Chain - TN - Nickel Plated	D-12
TN1016NP	0.750	Plastic Top Chain - TN - Nickel Plated	D-12
TN1143NP	0.750	Plastic Top Chain - TN - Nickel Plated	D-12
TN1270NP	0.750	Plastic Top Chain - TN - Nickel Plated	D-12
TN1905NP	0.750	Plastic Top Chain - TN - Nickel Plated	D-12
TN826NP-LAMBDA	0.750	Plastic Top Chain - TN - Nickel Plated - Lambda	D-12
TN1016NP-LAMBDA	0.750	Plastic Top Chain - TN - Nickel Plated - Lambda	D-12
TN1143NP-LAMBDA	0.750	Plastic Top Chain - TN - Nickel Plated - Lambda	D-12
TN1270NP-LAMBDA	0.750	Plastic Top Chain - TN - Nickel Plated - Lambda	D-12
TN1905NP-LAMBDA	0.750	Plastic Top Chain - TN - Nickel Plated - Lambda	D-12
TN826SS	0.750	Plastic Top Chain - TN - Stainless Steel	D-12
TN1016SS	0.750	Plastic Top Chain - TN - Stainless Steel	D-12
TN1143SS	0.750	Plastic Top Chain - TN - Stainless Steel	D-12
TN1270SS	0.750	Plastic Top Chain - TN - Stainless Steel	D-12
TN1905SS	0.750	Plastic Top Chain - TN - Stainless Steel	D-12
TN826PC	0.750	Plastic Top Chain - TN - Poly-Steel	D-12
TTUP826	1.500	Plastic Top Chain - TTUP - Curved Movement	D-13
TTUP826P	1.500	Plastic Top Chain - TTUP - Curved Movement	D-13
TTUP1143	1.500	Plastic Top Chain - TTUP - Curved Movement	D-13
TTUP1143P	1.500	Plastic Top Chain - TTUP - Curved Movement	D-13
TTUP1905	1.500	Plastic Top Chain - TTUP - Curved Movement	D-13
TPU826	1.500	Plastic Top Chain - TPU - Curved Movement	D-14
TPU826P	1.500	Plastic Top Chain - TPU - Curved Movement	D-14
MTPU826T	1.500	Plastic Top Chain - MTPU - Curved Movement	D-15
TPSR826T	1.250	Plastic Top Chain - TPSR - Curved Movement	D-16
TNU826	0.750	Plastic Top Chain - TNU - Curved Movement	D-17
TNU1143	0.750	Plastic Top Chain - TNU - Curved Movement	D-17
TNU1270	0.750	Plastic Top Chain - TNU - Curved Movement	D-17
TNU826NP	0.750	Plastic Top Chain - TNU - Nickel Plated - Curved Movement	D-17
TNU1143NP	0.750	Plastic Top Chain - TNU - Nickel Plated - Curved Movement	D-17
TNU1270NP	0.750	Plastic Top Chain - TNU - Nickel Plated - Curved Movement	D-17
TNU826AS	0.750	Plastic Top Chain - TNU - Stainless Steel - Curved Movement	D-17
TNU1143AS	0.750	Plastic Top Chain - TNU - Stainless Steel - Curved Movement	D-17
TNU1270AS	0.750	Plastic Top Chain - TNU - Stainless Steel - Curved Movement	D-17
RF06B-SC	0.375	Plastic Snap Cover Chain	D-18
RS40-SC	0.500	Plastic Snap Cover Chain	D-18
RS50-SC	0.625	Plastic Snap Cover Chain	D-18
RS60-SC	0.750	Plastic Snap Cover Chain	D-18

Chain Number	Pitch P	Chain Type	Page #
RS80-SC	1.000	Plastic Snap Cover Chain	D-18
RS100-SC	1.250	Plastic Snap Cover Chain	D-18
RSC40-LAMBDA-SC	0.500	Plastic Snap Cover Chain - Lambda	D-18
RSC50-LAMBDA-SC	0.625	Plastic Snap Cover Chain - Lambda	D-18
RSC60-LAMBDA-SC	0.750	Plastic Snap Cover Chain - Lambda	D-18
RSC80-LAMBDA-SC	1.000	Plastic Snap Cover Chain - Lambda	D-18
RSC100-LAMBDA-SC	1.250	Plastic Snap Cover Chain - Lambda	D-18
RF06BSS-SC	0.375	Plastic Snap Cover Chain - Stainless Steel	D-18
RS40SS-SC	0.500	Plastic Snap Cover Chain - Stainless Steel	D-18
RS50SS-SC	0.625	Plastic Snap Cover Chain - Stainless Steel	D-18
RS60SS-SC	0.750	Plastic Snap Cover Chain - Stainless Steel	D-18
RS80SS-SC	1.000	Plastic Snap Cover Chain - Stainless Steel	D-18
RS100SS-SC	1.250	Plastic Snap Cover Chain - Stainless Steel	D-18
ST305SS	0.375	Plastic Roller Table Chain - ST - Stainless Steel	D-19
ST310SS	0.375	Plastic Roller Table Chain - ST - Stainless Steel	D-19
ST315SS	0.375	Plastic Roller Table Chain - ST - Stainless Steel	D-19
ST320SS	0.375	Plastic Roller Table Chain - ST - Stainless Steel	D-19
ST404SS	0.500	Plastic Roller Table Chain - ST - Stainless Steel	D-19
ST406SS	0.500	Plastic Roller Table Chain - ST - Stainless Steel	D-19
ST408SS	0.500	Plastic Roller Table Chain - ST - Stainless Steel	D-19
ST410SS	0.500	Plastic Roller Table Chain - ST - Stainless Steel	D-19
ST412SS	0.500	Plastic Roller Table Chain - ST - Stainless Steel	D-19
ST414SS	0.500	Plastic Roller Table Chain - ST - Stainless Steel	D-19
ST416SS	0.500	Plastic Roller Table Chain - ST - Stainless Steel	D-19
ST504SS	0.625	Plastic Roller Table Chain - ST - Stainless Steel	D-19
ST506SS	0.625	Plastic Roller Table Chain - ST - Stainless Steel	D-19
ST508SS	0.625	Plastic Roller Table Chain - ST - Stainless Steel	D-19
ST510SS	0.625	Plastic Roller Table Chain - ST - Stainless Steel	D-19
ST512SS	0.625	Plastic Roller Table Chain - ST - Stainless Steel	D-19
ST514SS	0.625	Plastic Roller Table Chain - ST - Stainless Steel	D-19
ST516SS	0.625	Plastic Roller Table Chain - ST - Stainless Steel	D-19
ST518SS	0.625	Plastic Roller Table Chain - ST - Stainless Steel	D-19
ST520SS	0.625	Plastic Roller Table Chain - ST - Stainless Steel	D-19
ST522SS	0.625	Plastic Roller Table Chain - ST - Stainless Steel	D-19
ST524SS	0.625	Plastic Roller Table Chain - ST - Stainless Steel	D-19
ST404NP	0.500	Plastic Roller Table Chain - ST - Nickel Plated	D-19
ST406NP	0.500	Plastic Roller Table Chain - ST - Nickel Plated	D-19
ST408NP	0.500	Plastic Roller Table Chain - ST - Nickel Plated	D-19
ST410NP	0.500	Plastic Roller Table Chain - ST - Nickel Plated	D-19
ST412NP	0.500	Plastic Roller Table Chain - ST - Nickel Plated	D-19
ST414NP	0.500	Plastic Roller Table Chain - ST - Nickel Plated	D-19
ST416NP	0.500	Plastic Roller Table Chain - ST - Nickel Plated	D-19
ST504NP	0.625	Plastic Roller Table Chain - ST - Nickel Plated	D-19
ST506NP	0.625	Plastic Roller Table Chain - ST - Nickel Plated	D-19
ST508NP	0.625	Plastic Roller Table Chain - ST - Nickel Plated	D-19
ST510NP	0.625	Plastic Roller Table Chain - ST - Nickel Plated	D-19
ST512NP	0.625	Plastic Roller Table Chain - ST - Nickel Plated	D-19
ST514NP	0.625	Plastic Roller Table Chain - ST - Nickel Plated	D-19
ST516NP	0.625	Plastic Roller Table Chain - ST - Nickel Plated	D-19
ST518NP	0.625	Plastic Roller Table Chain - ST - Nickel Plated	D-19
ST520NP	0.625	Plastic Roller Table Chain - ST - Nickel Plated	D-19
ST522NP	0.625	Plastic Roller Table Chain - ST - Nickel Plated	D-19
ST524NP	0.625	Plastic Roller Table Chain - ST - Nickel Plated	D-19
RT305SS	0.375	Plastic Roller Table Chain - RT - Stainless Steel	D-20
RT310SS	0.375	Plastic Roller Table Chain - RT - Stainless Steel	D-20
RT315SS	0.375	Plastic Roller Table Chain - RT - Stainless Steel	D-20
RT320SS	0.375	Plastic Roller Table Chain - RT - Stainless Steel	D-20
RT404SS	0.500	Plastic Roller Table Chain - RT - Stainless Steel	D-20
RT406SS	0.500	Plastic Roller Table Chain - RT - Stainless Steel	D-20
RT408SS	0.500	Plastic Roller Table Chain - RT - Stainless Steel	D-20
RT412SS	0.500	Plastic Roller Table Chain - RT - Stainless Steel	D-20
RT416SS	0.500	Plastic Roller Table Chain - RT - Stainless Steel	D-20
RT504SS	0.625	Plastic Roller Table Chain - RT - Stainless Steel	D-20
RT508SS	0.625	Plastic Roller Table Chain - RT - Stainless Steel	D-20
RT512SS	0.625	Plastic Roller Table Chain - RT - Stainless Steel	D-20
RT516SS	0.625	Plastic Roller Table Chain - RT - Stainless Steel	D-20
RT518SS	0.625	Plastic Roller Table Chain - RT - Stainless Steel	D-20
RT520SS	0.625	Plastic Roller Table Chain - RT - Stainless Steel	D-20
RT524SS	0.625	Plastic Roller Table Chain - RT - Stainless Steel	D-20
RT604SS	0.750	Plastic Roller Table Chain - RT - Stainless Steel	D-20
RT608SS	0.750	Plastic Roller Table Chain - RT - Stainless Steel	D-20
RT612SS	0.750	Plastic Roller Table Chain - RT - Stainless Steel	D-20
RT620SS	0.750	Plastic Roller Table Chain - RT - Stainless Steel	D-20
RT624SS	0.750	Plastic Roller Table Chain - RT - Stainless Steel	D-20
MP4-500	0.500	Plastic BeTop Chain - MP	D-21
BT08-830	1.000	Plastic BeTop Chain - BTO	D-22
RF25PC	0.250	Poly-Steel Roller Chain	D-23
RF35PC	0.375	Poly-Steel Roller Chain	D-23
RF40PC	0.500	Poly-Steel Roller Chain	D-23
RF50PC	0.625	Poly-Steel Roller Chain	D-23
RF60PC	0.750	Poly-Steel Roller Chain	D-23
RF40PC-SY	0.500	Poly-Steel Roller Chain - Corrosion Resistant	D-23
RF50PC-SY	0.625	Poly-Steel Roller Chain - Corrosion Resistant	D-23
RF60PC-SY	0.750	Poly-Steel Roller Chain - Corrosion Resistant	D-23

